

P-USP0-6 FLANGED ENDS
Indicator Post Style Stuffing box
2" Square Operating Nut

- 4", 6", 8", 10", 12" SIZES
- MEETS OR EXCEEDS ALL APPLICABLE REQUIREMENTS OF UL 262 AND FM 1120/1130 SPECIFICATIONS AND COMPLIES WITH NSF-61
- IRON BODY WITH FUSION EPOXY COATED INTERIOR & EXTERIOR SURFACES
- NON-RISING BRONZE STEM
- RUBBER ENCAPSULATED IRON WEDGE
- 200 PSIG (1379 KPA) MAXIMUM WORKING PRESSURE, 400 PSIG (2758 KPA) STATIC TEST
- TRIPLE O-RING SEAL STUFFING BOX (2 UPPER & 1 LOWER O-RINGS)
- EPOXY COATING MEETS OR EXCEEDS ANSI/AWWA C550 AND COMPLIES WITH NSF-61



PARTS LIST

Catalog Part No.	Description	Material	Material Standard
G-16	Bonnet Bolts & Nuts	Stainless Steel	Type 304
G-27	Wrench Nut	Cast Iron	ASTM A126 CL.B
G-41	Stuffing Box Bolts & Nuts	Stainless Steel	Type 304
G-49	Stem O-rings (3)	Rubber	ASTM D2000
G-152	Stuffing Box	Cast Iron	ASTM A126 CL.B
G-200	Wrench Nut Cap Screw	Stainless Steel	Type 304
G-201	Stuffing Box Seal	Rubber	ASTM D2000
G-203	Stem	Bronze	ASTM B138
G-205	Stem Nut	Bronze	ASTM B62
G-206	Guide Cap Bearings	Thermal Plastic	
G-208	Anti-friction Washers (2)	Thermal Plastic	
G-209	Wedge, Rubber Encapsulated	Cast Iron**	ASTM A126 CL.B
G-210	Bonnet	Cast Iron	ASTM A126 CL.B
G-211	Bonnet Gasket	Rubber	ASTM D2000
G-212	Body	Cast Iron	ASTM A126 CL.B

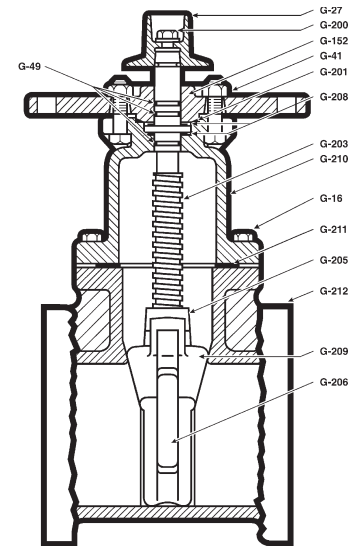

DIMENSIONS

Dimension*	Size				
	4"	6"	8"	10"	12"
A	14.19"	18.00"	21.50"	25.50"	28.62"
R	9.00"	11.00"	13.50"	16.00"	19.00"
FF	9.00"	10.50"	11.50"	13.00"	14.00"
E	12.00"	12.00"	12.00"	12.00"	12.00"
Q (Bore)	4.30"	6.30"	8.30"	10.30"	12.30"
UU	7.50"	9.50"	11.75"	14.25"	17.00"
B (number and size of holes)	8--.75"	8--.88"	8--.88"	12--1"	12--1"
Turns to open	14	20.5	26.5	33	38.5
Weight (lbs.)*	113	172	263	398	520

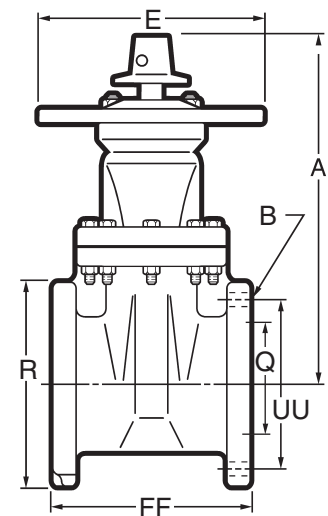

See page B-11 for ordering instructions.
NOTE: Flanged ends have 125 lb. American Standard End Flange Drilling, ANSI B16.1.
*All dimensions are in inches. All weights are in approximate pounds.
** Fully encapsulated in molded rubber with no iron exposed.