

P-USP0-16 (with M.J. Accessories+) **FLANGED X MECHANICAL JOINT ENDS**
P-USP0-19 (less M.J. Accessories) **Indicator Post Style Stuffing box**
2" Square Operating Nut

- 4", 6", 8", 10" AND 12" SIZES
- MEETS OR EXCEEDS ALL APPLICABLE REQUIREMENTS OF UL 262 AND FM 1120/1130 SPECIFICATIONS AND COMPLIES WITH NSF-61
- IRON BODY WITH FUSION EPOXY COATED INTERIOR & EXTERIOR SURFACES
- NON-RISING BRONZE STEM
- RUBBER ENCAPSULATED IRON WEDGE
- 200 PSIG (1379 KPA) MAXIMUM WORKING PRESSURE, 400 PSIG (2758 KPA) STATIC TEST
- TRIPLE O-RING SEAL STUFFING BOX (2 UPPER & 1 LOWER O-RINGS)
- EPOXY COATING MEETS OR EXCEEDS ANSI/AWWA C550 AND COMPLIES WITH NSF-61

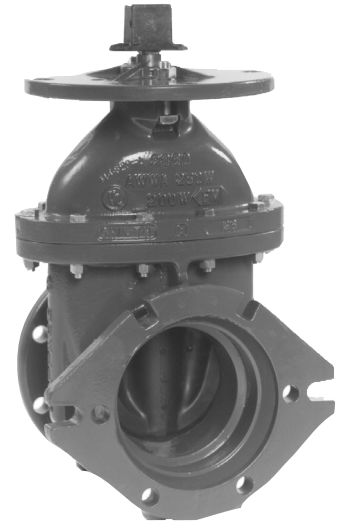

Options

- STAINLESS STEEL FASTENERS: TYPE 316
- ASTM B98-C66100/H02 STEM

PARTS LIST

Catalog Part No.	Description	Material	Material Standard
G-16	Bonnet Bolts & Nuts	Stainless Steel	Type 304
G-27	Wrench Nut	Cast Iron	ASTM A126 CL.B
G-41	Stuffing Box Bolts & Nuts	Stainless Steel	Type 304
G-49	Stem O-rings (3)	Rubber	ASTM D2000
G-152	Stuffing Box	Cast Iron	ASTM A126 CL.B
G-200	Wrench Nut Cap Screw	Stainless Steel	Type 304
G-201	Stuffing Box Seal	Rubber	ASTM D2000
G-203	Stem	Bronze	ASTM B138
G-205	Stem Nut	Bronze	ASTM B62
G-206	Guide Cap Bearings	Thermal Plastic	
G-208	Anti-friction Washers (2)	Thermal Plastic	
G-209	Wedge, Rubber Encapsulated	Cast Iron**	ASTM A126 CL.B
G-210	Bonnet	Cast Iron	ASTM A126 CL.B
G-211	Bonnet Gasket	Rubber	ASTM D2000
G-212	Body	Cast Iron	ASTM A126 CL.B

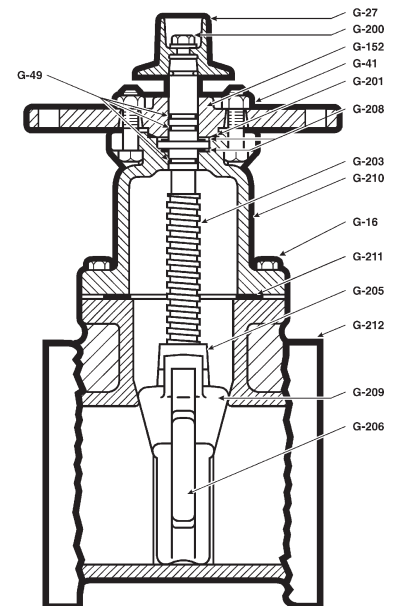

DIMENSIONS

Dimension*	Size				
	4"	6"	8"	10"	12"
A	14.19"	18.00"	21.50"	25.50"	28.62"
R	9.00"	11.00"	13.50"	16.00"	19.00"
FF	9.50"	11.00"	12.00"	13.88"	14.44"
E	12.00"	12.00"	12.00"	12.00"	12.00"
UU (Bolt Circle for FL)	7.50"	9.50"	11.75"	14.25"	17.00"
Q (Bore)	4.30"	6.30"	8.30"	10.30"	12.30"
OO (Bolt Circle for MJ)	7.50"	9.50"	11.75"	14.00"	16.25"
N	9.12"	11.12"	13.37"	15.62"	17.88"
L	2.50"	2.50"	2.50"	2.50"	2.50"
B (number and size of holes for FL)	8--.75"	8--.88"	8--.88"	12---1"	12---1"
O (number and size of holes for MJ)	4--.88"	6--.88"	6--.88"	8--.88"	8--.88"
Turns to open	14	20.5	26.5	33	38.5
Weight (lbs.)*	120	172	264	397	522

See page B-11 for ordering instructions.

NOTE: Flanged ends have 125 lb. American Standard End Flange Drilling, ANSI B16.1.

+ MJ accessories are included and palletized separately from valves.

*All dimensions are in inches. All weights are in approximate pounds.

**Fully encapsulated in molded rubber with no iron exposed.

