

**N.R.S. RESILIENT WEDGE  
GATE VALVES  
FL X MJ**



**UL / FM**

**P-USP1-16** (with M.J. Accessories+) **FLANGED X MECHANICAL JOINT ENDS**  
**P-USP1-19** (less M.J. Accessories) **Indicator Post Style Stuffing box**  
**2" Square Operating Nut**

- ❑ 14" AND 16" SIZES
- ❑ MEETS OR EXCEEDS ALL APPLICABLE REQUIREMENTS OF UL 262 AND FM 1120/1130 SPECIFICATIONS AND COMPLIES WITH NSF-61
- ❑ IRON BODY WITH FUSION EPOXY COATED INTERIOR & EXTERIOR SURFACES
- ❑ NON-RISING BRONZE STEM
- ❑ RUBBER ENCAPSULATED IRON WEDGE
- ❑ 250 PSIG (1723 KPA) MAXIMUM WORKING PRESSURE, 500 PSIG (3447 KPA) STATIC TEST
- ❑ TRIPLE O-RING SEAL STUFFING BOX (2 UPPER & 1 LOWER O-RINGS)
- ❑ EPOXY COATING MEETS OR EXCEEDS ANSI/AWWA C550 AND COMPLIES WITH NSF-61

**Options**

- ❑ STAINLESS STEEL FASTENERS: TYPE 304, TYPE 316
- ❑ ASTM B98-C66100/H02 STEM

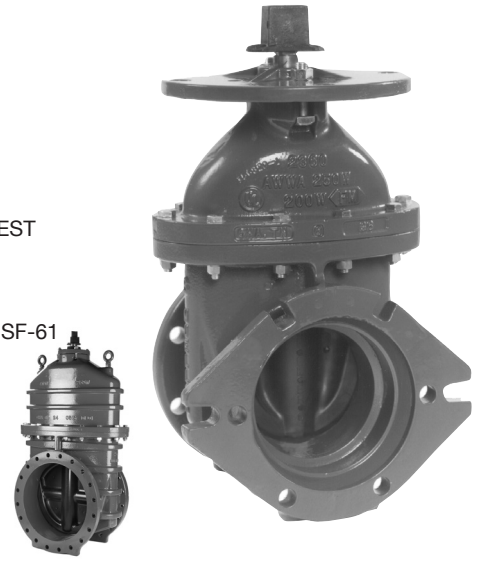

**PARTS LIST**

Catalog Part No.	Description	Material	Material Standard
G-16	Bonnet Bolts & Nuts	Carbon Steel	ASTM A307 Grad B, Zinc Plated
G-27	Wrench Nut	Cast Iron	ASTM A126 CL.B
G-41	Stuffing Box Bolts & Nuts	Carbon Steel	ASTM A307 Grad B, Zinc Plated
G-49	Stem O-rings (3)	Rubber	ASTM D2000
G-152	Stuffing Box	Ductile Iron	ASTM A536 Grade 65-45-12
G-200	Wrench Nut Cap Screw	Carbon Steel	ASTM A307 Grad B, Zinc Plated
G-201	Stuffing Box Seal	Rubber	ASTM D2000
G-203	Stem	Bronze	ASTM B138
G-205	Stem Nut	Bronze	ASTM B62
G-206	Guide Cap Bearings	Celcon	
G-208	Anti-friction Washers (2)	Brass	
G-209	Wedge, Rubber Encapsulated	Ductile Iron**	ASTM A536 Grade 65-45-12
G-210	Bonnet	Ductile Iron	ASTM A536 Grade 65-45-12
G-211	Bonnet Gasket	Rubber	ASTM D2000
G-212	Body	Ductile Iron	ASTM A536 Grade 65-45-12

14"-16" Body Style

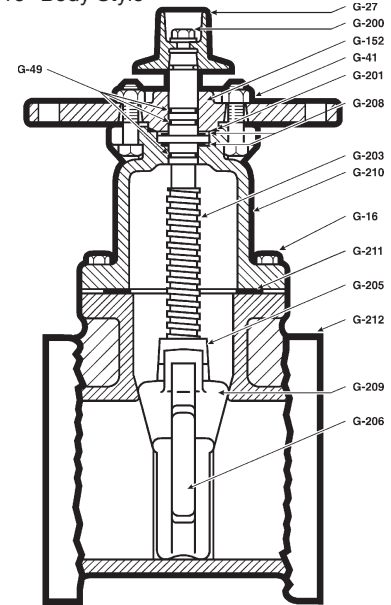

**DIMENSIONS**

Dimension*	Size	
	14"	16"
A	32.75"	37.88"
R	21.00"	23.50"
FF	17.41"	17.91"
E	12.00"	12.00"
UU (Bolt circle for FL)	18.75"	21.25"
Q (Bore)	14.38"	16.00"
OO (Bolt circle for MJ)	18.75"	21.00"
N	20.25"	22.56"
L	3.50"	3.50"
B (number and size of holes for FL)	12--1.12"	16--1.12"
O (number and size of holes for MJ)	10--.88"	12--.88"
Turns to open	43.5	49
Weight (lbs.)*	655	875

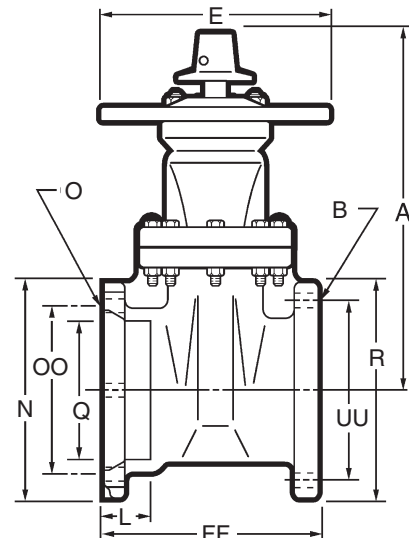

See page B-11 for ordering instructions.  
 NOTE: Flanged ends have 125 lb. American Standard End Flange Drilling, ANSI B16.1.  
 + MJ accessories are included and palletized separately from valves.  
 \*All dimensions are in inches. All weights are in approximate pounds.  
 \*\*Fully encapsulated in molded rubber with no iron exposed.