

3"-12" SWING TYPE LEVER AND WEIGHT CHECK VALVE DIMENSIONS - M.J. X M.J.

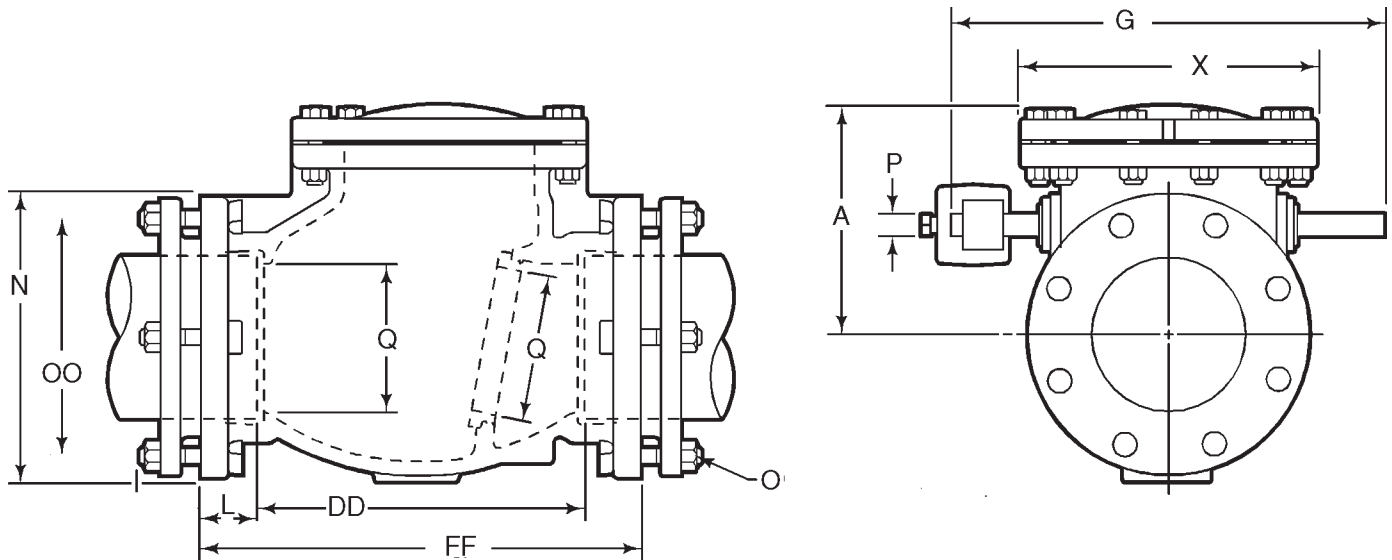

Dimension	Size*					
	3"	4"	6"	8"	10"	12"
N	7.50	9.13	11.31	13.63	15.81	18.06
OO (bolt circle diameter)	6.19	7.50	9.50	11.75	14.00	16.25
Q (bore)	3.38	4.00	6.00	8.00	10.00	12.00
O (number and size of bolts)	4--.63	8--.75	12--.75	12--.75	16--.75	16--.75
L	2.50	2.50	2.50	2.50	2.50	2.50
DD	8.00	10.00	12.50	15.00	17.75	20.50
FF	13.50	15.00	17.50	20.00	22.75	25.50
G	14.00	15.00	17.75	21.50	24.75	27.50
X	7.56	9.00	11.69	14.00	17.00	19.13
A	6.25	7.25	9.00	10.50	12.75	14.75
P	.63	.88	1.00	1.00	1.13	1.13

*Nominal

**All dimensions are in inches.