

# 2-1/2"-12 WEIGHT ASSISTED CUSHIONED SWING CHECK VALVE DIMENSIONS-FL. X FL.

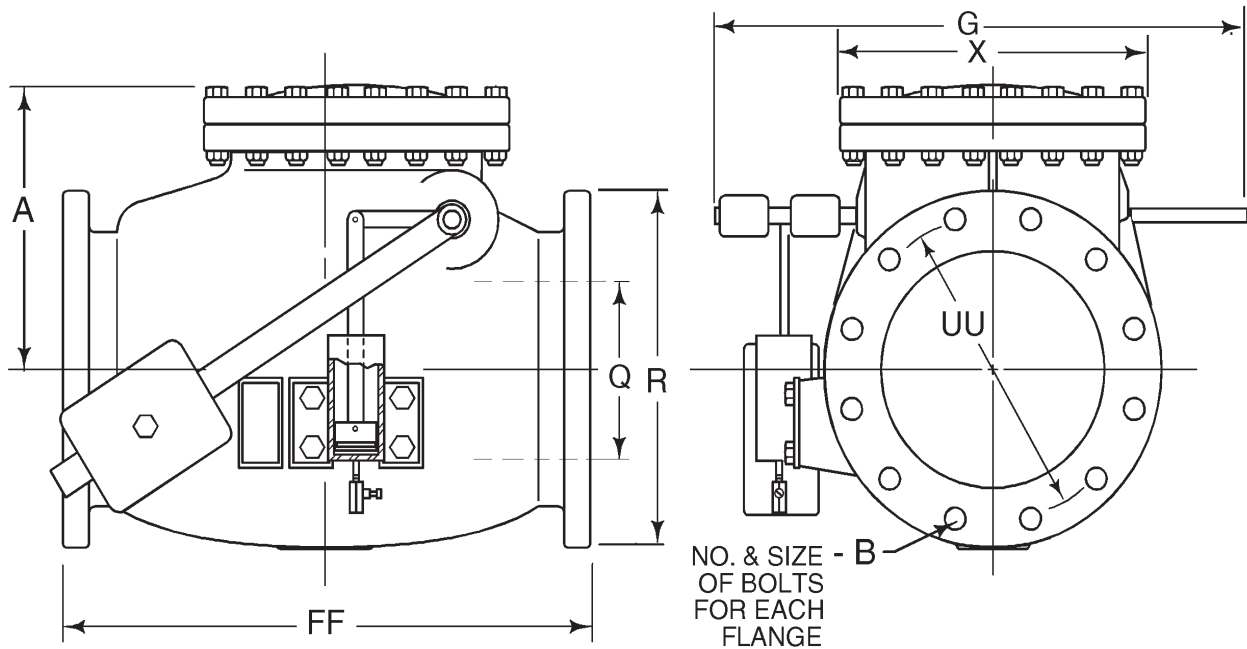

Dimension	Size*						
	2-1/2"	3"	4"	6"	8"	10"	12"
A	5.75	6.25	7.25	9.00	10.50	12.75	14.75
B (number and size of bolts)	4--.63	4--.63	8--.63	8--.75	8--.75	12--.88	12--.88
UU (bolt circle diameter)	5.50	6.00	7.50	9.50	11.75	14.25	17.00
R	7.00	7.50	9.00	11.00	13.50	16.00	19.00
FF	10.00	11.00	12.88	16.00	19.50	22.00	24.13
Q (bore)	2.50	3.00	4.00	6.00	8.00	10.00	12.00
G	13.50	15.50	16.25	19.25	23.00	27.00	28.56
X	6.94	7.56	9.00	11.69	14.00	17.00	19.13

\*Nominal

\*\*All dimensions are in inches.