

FIRE PROTECTION PRODUCTS

- ❑ "D" shaped Cast Iron Cover has directional flow arrow cast in. "D" shape assures cover will always be assembled to show correct flow direction.

- ❑ Cover Bolts and Nuts are electrogalvanized steel to resist corrosion.

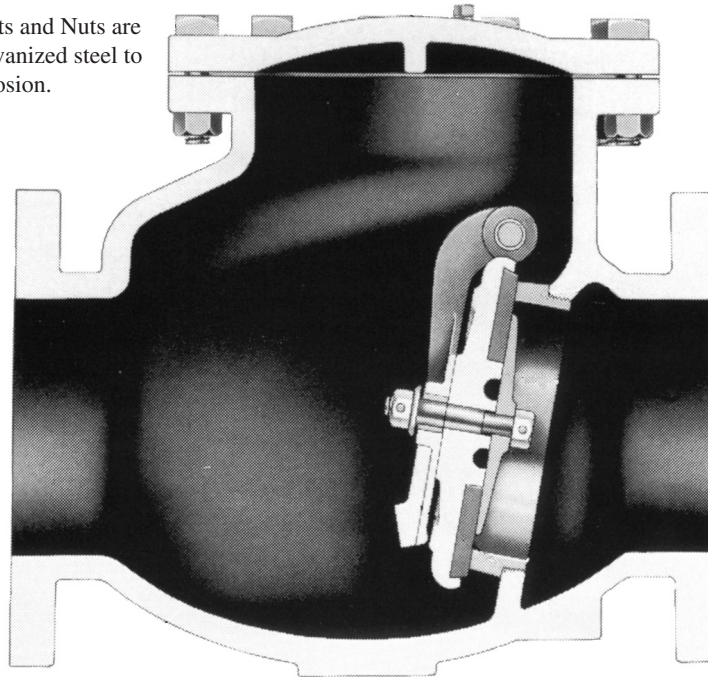

- ❑ All internal parts can be removed for inspection or repair without removing valve from line.

- ❑ Hinge Pin, Hinge Plug and Hinge Bushing are made from Brass and Bronze to reduce corrosion.

- ❑ Accurately machined Bronze Seat Ring.

- ❑ Disc available with either rubber cap or Bronze seat.

- ❑ Cast Iron Body is accurately cast and machined to provide long and trouble free service.

- ❑ Ductile Iron Clapper Arm provides long and trouble free services.

- ❑ MUELLER CO. also offers a full line of AWWA Type Check Valves. See MUELLER Water Works Catalog for further information.

The MUELLER® UL listed and F/M approved Check Valves are of the gravity operated, swing check design. These Check Valves are rugged in construction and simple in design.

The MUELLER Check Valves are designed to permit the removal of all parts through the top of the valve for inspection or replacement without removing the valve from the line.

An arrow on the cover indicates the direction of flow and since the cover is "D" shaped there is no possibility of reversing the cover thus insuring the directional arrow will always point in the direction of flow.

MUELLER Check Valves are bossed on both sides of the body for connecting by-passes and are also bossed at the bottom under the outlet and inlet ends for attaching drain valves.

These Check Valves are available with either rubber or bronze disc facings.