

A453-5 1/4" SENTINEL "250" W/ TWO HOSE NOZZLES & ONE 5" STORZ NOZZLE
AWWA C502 COMPLIANT - 250 P.S.I. W.P. - 500 P.S.I. TEST, UL/FM LISTED

DWG. FH 242

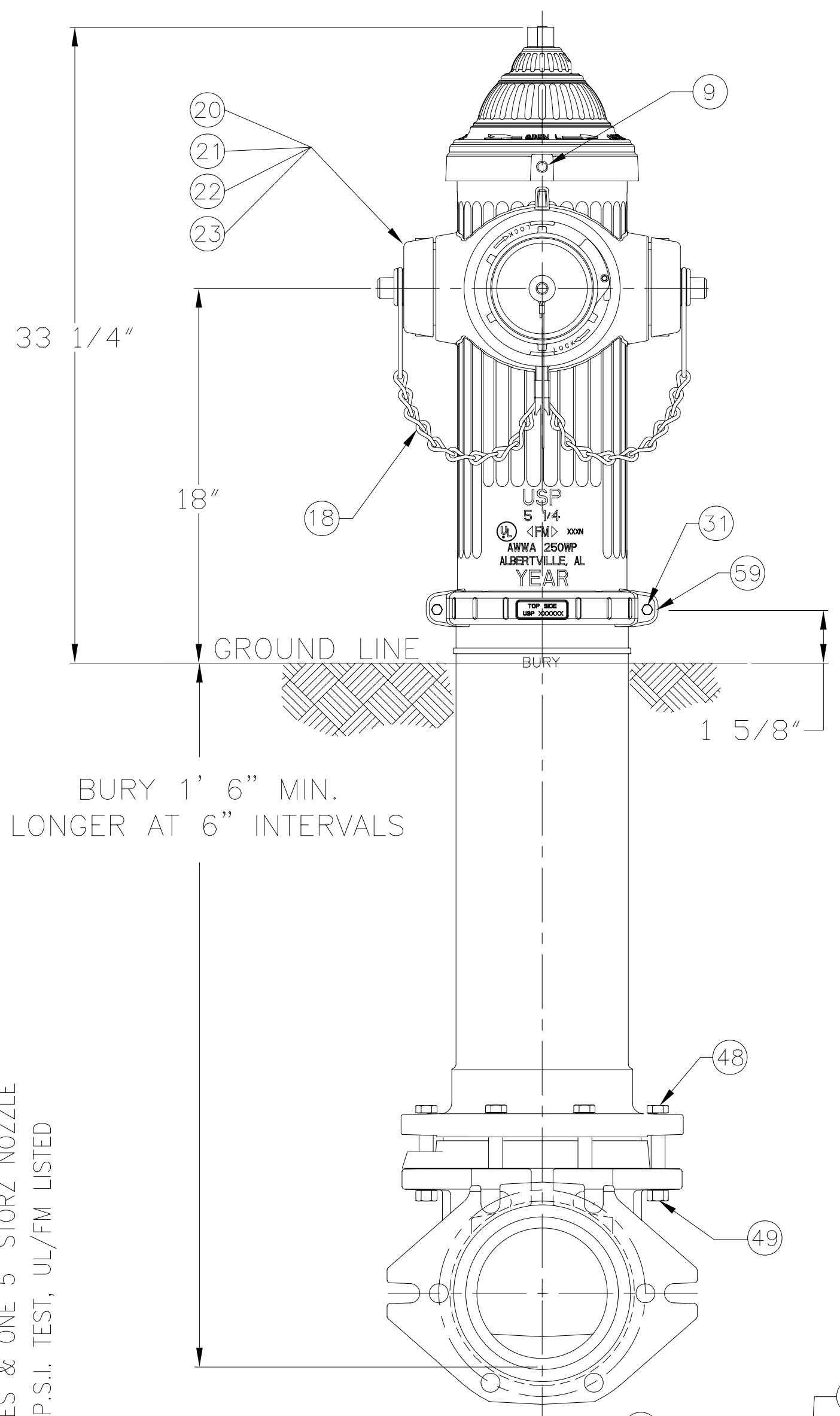

BURY 1' 6" MIN.
LONGER AT 6" INTERVALS

PARTS LIST				
ITEM	DESCRIPTION	REQ'D	MATERIAL	A.S.T.M.
1	OPERATING NUT	1	DUCTILE IRON	A-536
2	OPERATING NUT SEAL	1	RUBBER	BUNA N 70 DURO
3	OPERATING NUT LOCKING PIN	1	STEEL	
4	LUBRICANT (IN CHAMBER)	1	DIANA 2100	FORSYTHE
5	TRAVEL NUT STOP	1	STEEL	A-307 GRADE B
6	HOLD DOWN NUT	1	BRONZE	A-584 C8345
7	HOLD DOWN NUT SCREW	1	STEEL	A-574
8	BONNET	1	DUCTILE IRON	A-536
9	BONNET LOCKING SCREW	1	STAINLESS STEEL	TYPE 18-8
10	BONNET SEAL	1	RUBBER	BUNA N 70 DURO
11	O-RING	1	RUBBER	BUNA N 70 DURO
12	BONNET-REVOLVING NUT "O" RINGS	2	RUBBER	BUNA N 70 DURO
13	REVOLVING NUT	1	BRONZE	A-584 C862
14	INNER REVOLVING NUT "O" RINGS	2	RUBBER	BUNA N 70 DURO
15	GASKET	1	RUBBER	D-2000
16	PUMPER NOZZLE O-RING	1	RUBBER	D-2000 BUNA N
17	5" STORZ PUMPER CAP	1	ALUMINUM	B-108 ALLOY 356-T6
18	CAP CHAINS	2	STEEL	ELECTRO GALV.
19	5" STORZ PUMPER NOZZLE	1	ALUMINUM BRONZE	B-148 ALLOY C95200
20	HOSE NOZZLE	2	BRONZE	B-584 ALLOY 844
21	HOSE NOZZLE CAP GASKET	2	RUBBER	D-2000 NEOPRENE

SEE CAT. RECORD FOR RESPECTIVE PARTS OR SUB. ASS'YS

ITEM	DESCRIPTION	REQ'D	MATERIAL	A.S.T.M.
22	HOSE NOZZLE "O" RING	2	RUBBER	D-2000 BUNA N 70 DURO
23	HOSE NOZZLE CAP	2	CAST IRON	A-126 CLASS B
24	ROD UPPER	1	HOT ROLLED STEEL	
25	STANDPIPE UPPER	1	DUCTILE IRON	A-536
26	ROD COUPLING (FRANGIBLE)	1	STAINLESS STEEL	A-890 1.5% SILICON MAX.
27	COTTER PIN	2	STAINLESS STEEL	A-276 302
28	CLEVIS PIN	2	STAINLESS STEEL	A-276 305
29	STANDPIPE COUPLING SEAL	1	RUBBER	BUNA N 70 DURO
30	SP. COUPLING HALVES	2	CAST IRON	A-126 CLASS B
31	STANDPIPE COUPLING BOLTS	2	STAINLESS STEEL	A-194 316
32	VALVE ROD LOWER	1	HOT ROLLED STEEL	
33	STANDPIPE LOWER	1	CAST IRON	A-126 CLASS B
34	TOP PLATE PIN-SHEAR PROOF	1	STAINLESS STEEL	A-276 302
35	UPPER VALVE PLATE	1	BRONZE	B-584 ALLOY 844
36	DRAIN VALVE FACING	2	H.D. POLYETHYLENE	LS 5660-00
37	DRAIN VALVE FACING SCREW	4	STAINLESS STEEL	A-276 302
38	BOTTOM SEAT "O" RING	1	RUBBER	D-2000 BUNA N 70 DURO
39	DRAIN RING	1	BRONZE	B-584 ALLOY 844
40	SEAT RING	1	BRONZE	B-584 ALLOY 844
41	DRAIN RING HOUSING	1	CAST IRON	A-126 CLASS B
42	DRAIN RING HOUSING O-RING	1	RUBBER	D-2000 BUNA N 70 DURO
43	MAIN VALVE	1	RUBBER	D-2000 NATURAL

ITEM	DESCRIPTION	REQ'D	MATERIAL	A.S.T.M.
44	LOWER VALVE PLATE	1	CAST IRON	A-126 CLASS B
45	STORZ CAP CABLE	1	STAINLESS STEEL	
46	CHAIN HOOK	1	STEEL	ELECTRO GALV.
47	UPPER STEM PIN	1	STAINLESS STEEL	A-276 302
48	HEX BOLT	6	STEEL	A-307 ELECTROGALV. GR. B
49	HEX NUT	6	STEEL	A-307 ELECTROGALV. GR. B
50	SHOE	1	DUCTILE IRON	A-536 65-45-12
* 51	PIPE GLAND	1	CAST IRON	A-126 CLASS B
* 52	TOP SEAT O-RING	1	RUBBER	D-2000 BUNA N 70 DURO
* 53	MECH. JOINT GASKET	1	RUBBER	D-2000 R-42
* 54	T-HEAD BOLT	6	STEEL	A-242 TYPE 1
* 55	HEX NUT	6	STEEL	A-242 TYPE 1
56	ANTI-FRICTION BEARING	1	DELIN 500	DUPONT
57	SLEEVE	1	COPPER	B-75 ALLOY 122
58	STEM O-RING	1	RUBBER	D-2000 BUNA N
59	STANDPIPE COUPLING NUTS	2	STAINLESS STEEL	A-193 316
* 60	NOZZLE LOCKS	2	STAINLESS STEEL	A-276 305 OR 410

* NOT SHOWN

NOTE: SIZE AND STYLE OF OPERATING NUT, SHOE SIZE, AND THREADING OF NOZZLES IS PER CUSTOMER SPECS.

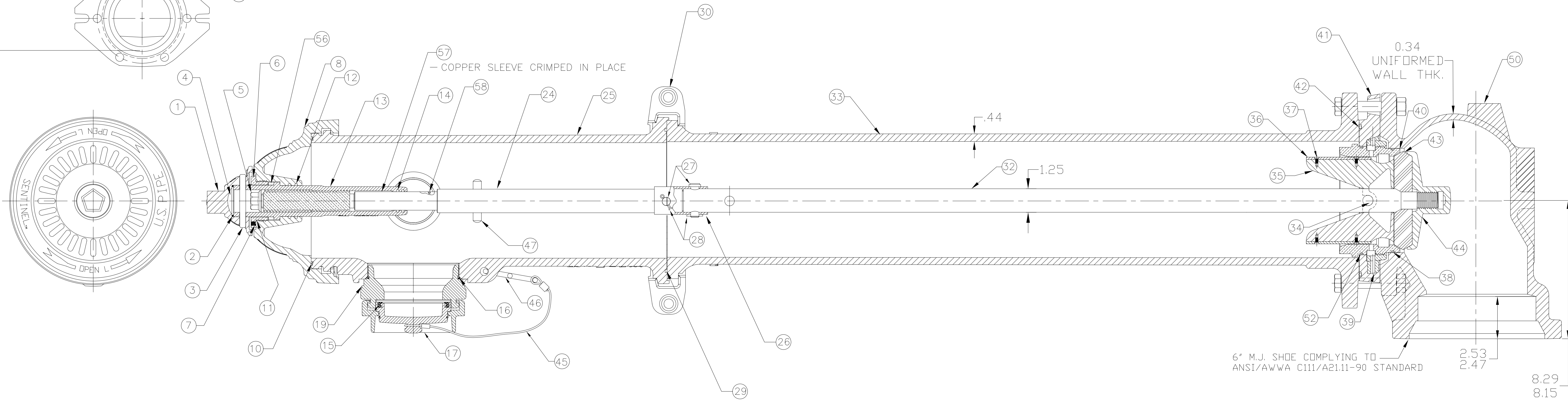

(MILLIMETER) INCH INITIAL RELEASE DRFT'R ANC 07-08-09 CHK'R APP E.O. NUMBER		TOLERANCES - MACHINING UNLESS OTHERWISE NOTED BREAK EDGES FINISH SURFACES MACH. .006/016 125 FRACTIONS ±1/64 DECIMALS 2 PL ±.025 3 PL ±.005 ANGLES ±1°		UNITED STATES PIPE & FOUNDRY THIRD ANGLE PROJECTION PURCH. FINISH REF. NO. SCALE STK. NO. SEE TABLE	
U.S. Pipe DESCR. 5 1/4" SENTINEL "250" W/ TWO HOSE NOZZLES ONE 5" STORZ NOZZLE		SEE TABLE REVISION NUMBER A FH 242		SHEET 1 OF 1	

REV.	DESCRIPTION	REF.	DRFT'R	CHK'R	APP	DATE
A	ADD AWWA C502 COMPLIANT, UL/FM LISTED, 250 PSI W.P. & 500 PSI TESTED		ANC			7-10-09