

14"-48" A-USP1 D.I. RESILIENT WEDGE GATE VALVE - M.J. x F.L.



17

Rev. 1-06

- Catalog number–
A-USP1-16 mechanical joint x flanged ends (with accessories unassembled)
A-USP1-19 mechanical joint x flanged ends (less accessories)
- Sizes – 14", 16", 18", 20", 24", 30", 36", 42", 48"
- Meets or exceeds all applicable requirements of ANSI/AWWA C515 Standard, UL Listed, FM Approved, and certified to ANSI/NSF 61.
- Flanged end dimensions and drilling comply with ANSI B16.1, class 125
- Mechanical joint end complies with ANSI/AWWA C111 Standard
- Ductile iron body and bonnet with nominal 10 mils fusion epoxy coated interior and exterior surfaces; 42" and 48" valves coated with Tnemec liquid epoxy.
- Epoxy coating meets or exceeds all applicable requirements of ANSI/AWWA C550 Standard and is certified to ANSI/NSF 61.
- Ductile iron wedge, symmetrical & fully encapsulated with molded rubber; no exposed iron.
- Non-rising stem (NRS)
- Triple O-ring seal stuffing box (2 upper & 1 lower O-ring)
- 2" square wrench nut (optional bevel or spur gearing) – open left or open right
 30" - 48" require a Spur Gear or Bevel Gear
- 250 psig (1723 kPa) maximum working pressure, 500 psig (3447 kPa) static test pressure
- 14" and 16" sizes – UL Listed, FM Approved: 250 psig (1723 kPa)

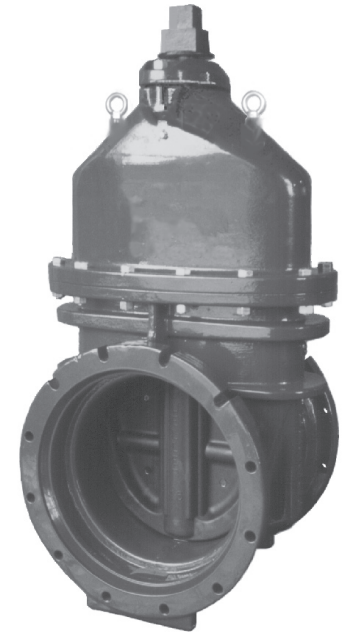

A-USP1-19

Options

See page 26 for more information on Resilient Wedge Gate Valve options

- Position indicators
- ASTM B98-C66100/H02 stem: 14"-16"
 ASTM B763-C99500: 18"- 48"
- Stainless steel fasteners: Type 304, Type 316
- Bypass 18" - 48" (2" on 18"-20"; 2.5" on 24";
 3" on 30"- 48")
- Handwheel
- Spur or bevel geared actuator

Resilient wedge gate valve parts

Catalog Part No.	Description	Material	Material standard
G-16	Bonnet Bolts & Nuts	Carbon Steel	ASTM A307 Grade B, Zinc Plated
G-41	Stuffing Box Bolts & Nuts	Carbon Steel	ASTM A307 Grade B, Zinc Plated
G-49	Stem O-rings (3)	Rubber	
G-200	Wrench Nut Cap Screw	Carbon Steel	ASTM A307 Grade B, Zinc Plated
G-201	Stuffing Box O-Ring Seal	Rubber	
G-202	Wrench Nut	Cast Iron	ASTM A126 CL.B
G-203	Stem	Bronze	ASTM B138**
G-204	Hand Wheel (not shown)	Cast Iron	ASTM A126 CL.B
G-205	Stem Nut	Bronze	ASTM B62
G-206	Guide Cap Bearings	Celcon	
G-207	Stuffing Box	Ductile Iron	ASTM A536
G-208	Anti-friction Washers (2)	Brass	
G-209	Wedge, Rubber Encapsulated	Ductile Iron* SBR†	ASTM A536 --
G-210	Bonnet	Ductile Iron	ASTM A536
G-211	Bonnet O-ring	Rubber	
G-212	Body	Ductile Iron	ASTM A536

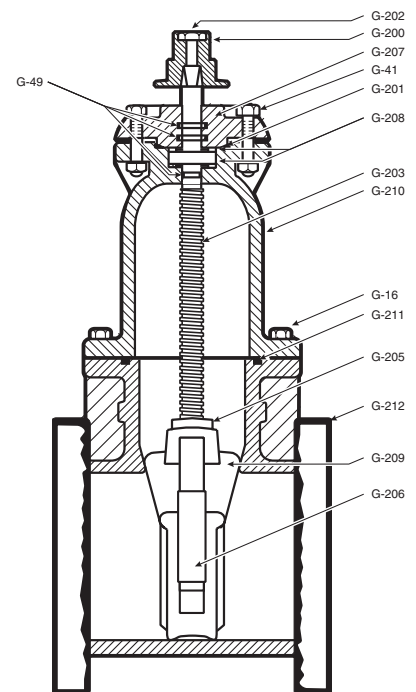

* Fully encapsulated in molded rubber with no iron exposed

**18" - 48" ASTM B584

†42" and 48" EPDM standard

SEE PAGE 27 FOR ORDERING INSTRUCTIONS