

PARTS LIST

ITEM	DESCRIPTION	REQ'D	MATERIAL	ASTM	NOTES
1	CAP SCREW	1	316 STAINLESS STEEL	A193	
2	WRENCH NUT	1	CAST IRON (SEE NOTE 4)	A126	CLASS B
3	BEVEL GEAR UNIT	1	(SEE NOTE 5)		
4	DRIVE SLEEVE	1	BRASS		
5	KEY	1	STEEL		
6	CAP SCREW	4	316 STAINLESS STEEL	A193	
7	GASKET	1	RUBBER	D2000	
8	ADAPTER	1	STEEL	A36	
9	GASKET	1	RUBBER	D2000	
10	STUFFING BOX	1	STEEL	A36	
11	HEX BOLT & NUT	4	316 STAINLESS STEEL	A193/A194	
12	O-RING	1	RUBBER	D2000	EPDM
13	STEM	1	BRONZE		SEE NOTE 1
14	O-RING	3	RUBBER	D2000	EPDM
15	BONNET BUSHING	1	BRONZE	B62	ALLOY C83600
16	O-RING	1	RUBBER	D2000	EPDM
17	WASHER	2	BRASS		
18	HEX BOLT & NUT	4	316 STAINLESS STEEL	A193/A194	
19	BONNET	1	DUCTILE IRON	A536	GR. 65-45-12
20	EYEBOLT	2	STEEL		GALVANIZED
21	O-RING	1	RUBBER	D2000	EPDM
22	HEX BOLT & NUT	"R"	316 STAINLESS STEEL	A193/A194	
23	DISC NUT	1	BRONZE	B62	ALLOY C83600
24	DISC	1			SEE NOTE 2
25	GUIDE CAP	2	CELCON		M90
26	BODY - M.J. ENDS	1	DUCTILE IRON	A536	GR. 65-45-12
27	PIPE NIPPLE W/FLG	1	STEEL		
28	PIPE NIPPLE W/FLG	1	STEEL		
29	BY-PASS VALVE	1			SEE NOTE 3
30	90° ELBOW	2	CAST STEEL		
31	FLANGE GASKET	5	RUBBER	D2000	
32	SPACER	1	STEEL	A36	
33	HEX BOLT	12	316 STAINLESS STEEL	A193	
34	HEX NUT	20	316 STAINLESS STEEL	A194	
35	STUD	4	316 STAINLESS STEEL	A193	
36	FLG x FLG BODY	1	DUCTILE IRON	A536	GR. 65-45-12
37	FLG x MJ BODY	1	DUCTILE IRON	A536	GR. 65-45-12
38	PIPE PLUG	2	SUPPLIED WHEN TAPPED		

POSITION INDICATOR PARTS LIST

ITEM	DESCRIPTION	REQ'D	MATERIAL	ASTM	NOTES
44	LOCK WASHER	1	STEEL		
45	GASKET	1	RUBBER		
46	WINDOW	1	PLEXI GLASS		
47	POINTER	1	BRONZE	B138A	ALLOY 676
48	DECAL	1			
49	HOUSING	1	STEEL		
50	INDICATOR STEM	1	BRONZE		
51	CAP SCREW	6	ST. STEEL		

- NOTES:**
- 1) 18" TO 24" VALVES - BRONZE ASTM B584 ALLOY 86400 OR 86500
 - 2) RUBBER ENCAPSULATED DUCTILE IRON DISC
RUBBER - EPDM ASTM D2000
DUCTILE IRON ASTM A536 GRADE 65-45-12
 - 3) BY-PASS VALVE
FOR 18" & 20" SIZES - 2" - RWGV - FLANGE ENDS
FOR 24" SIZE - 2.5" - RWGV - FLANGE ENDS
FOR 30" & 36" SIZES - 3" - RWGV - FLANGE ENDS
BY-PASS VALVES ARE EQUIPPED WITH 2" SQUARE WRENCH NUTS OR 6" DIA. HANDWHEELS OPEN LEFT OR RIGHT AS REQUIRED
 - 4) MANUFACTURER'S OPTION TO UPGRADE MATERIAL TO DUCTILE IRON A536 GRADE 65-45-12
 - 5) VALVES WILL BE FURNISHED WITH ONE OF THE LISTED OPERATORS AT THE MANUFACTURER'S DISCRETION.
18" - 24" MASTERGEAR OR ROTORK
30" - 36" LIMITORQUE OR ROTORK

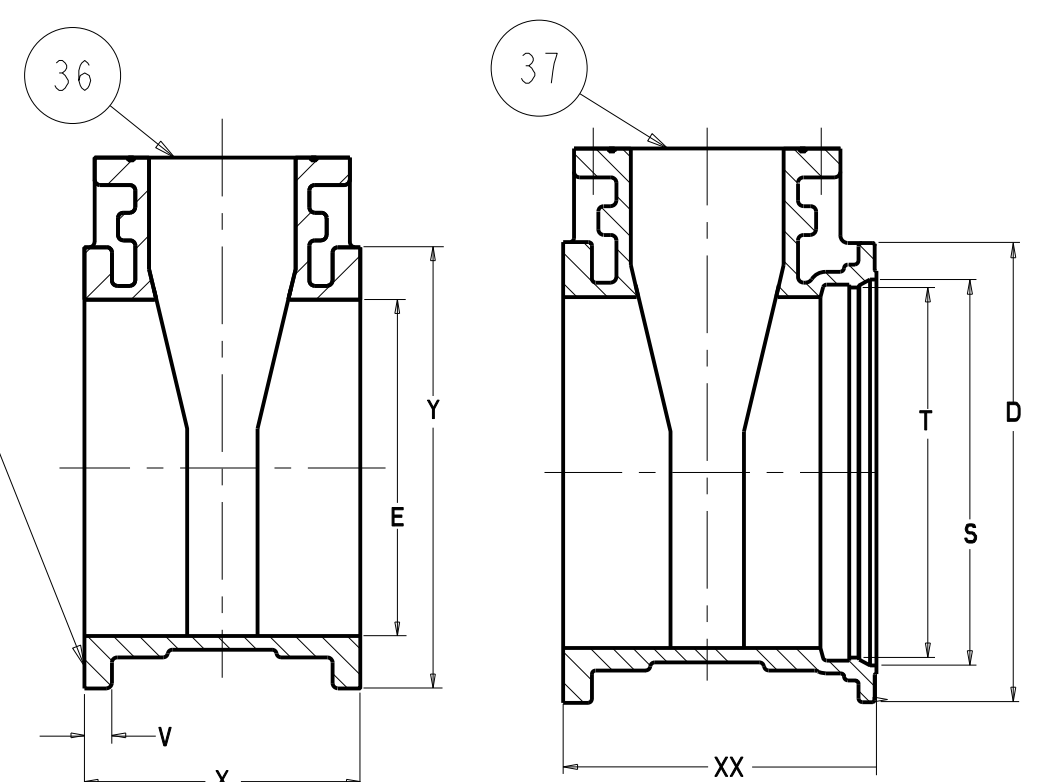

FLANGE END
"AA" - NO. & SIZE BOLT HOLES
EQUALLY SPACED ON "BB" - DIA. B.C.

VALVE SIZE	A	B	C	D	E	F	G	H	J	K	L	M	N	P	R	S	T	U	V	W	X	XX	Y	Z	AA	BB	URNS TO OPEN LIMITORQUE MASTERGEAR	URNS TO OPEN ROTORK
18	44.50	46.06	30.50	24.88	18.38	21.50	32.50	7.96	9.88	21.00	1.06	8.50	12 - .88	23.25	12	20.74	19.64	5.00	1.69	10.12	17.00	19.00	25.00	12.00	16 - 1.25	22.75	257	228
20	47.69	49.25	33.75	27.25	20.38	22.50	33.50	7.96	9.88	21.50	1.60	8.50	14 - .88	25.50	12	22.84	21.74	5.00	1.78	10.12	18.00	19.75	27.50	12.00	20 - 1.25	25.00	284	252
24	54.06	55.50	39.50	31.88	24.38	25.06	37.31	7.96	12.38	23.50	1.12	10.31	16 - .88	30.00	16	27.05	25.94	6.00	2.00	12.75	20.00	21.75	32.00	12.00	20 - 1.38	29.50	338	300
30	64.93	66.52	48.00	39.53	30.38	28.68	40.74	9.85	12.38	33.50	1.25	11.39	20 - 1.125	36.88	20	33.47	32.18	7.08	2.12	12.75	26.00	29.75	38.75	18.00	28 - 1.38	36.00	372	372
36	77.19	78.75	56.50	46.41	36.38	32.04	44.37	9.85	12.38	37.50	1.45	12.81	24 - 1.125	43.75	24	39.77	38.48	8.50	2.37	12.75	30.00	33.75	46.00	18.00	32 - 1.63	42.75	444	444

DR. ST.	CAP	11/1/05	UNLESS OTHERWISE NOTED	THIRD ANGLE PROJECTION	C.D. NO.
CHKD.	PSG	11/1/05	BREAK CAST CORNERS!		PART. NO.
ENGR.	RWV	11/1/05	BREAK MACH CORNERS!		
MFR.			TOLERANCES	PURCH. NO.	FINISH
INFO.			UNLESS OTHERWISE NOTED	REF. NO.	ASSEMBLY
TOOL.			L INEAR	ANGULAR	NONE
FDRT.			±	±	STR. NO.
NOTED					
MAT. L			DESCR.		NUMBER
UNITED STATES PIPE AND FOUNDRY CO. CHATTANOOGA, TENNESSEE			18"-36" RWGV'S W/ OPT. E302 M.J. MJ, FLXFL & FLX MJ ENDS W/ BEVEL GEARING - W/ BTM BY-PASS		U6702-E302

APPROVED
By Nicholas Franklin at 3:22 pm, Aug 18, 2009

U6702-E302