

4 IN - 8 IN C-USPO-42 RESILIENT WEDGE CUT-IN VALVE LESS ACCESSORIES
 NRS - AWWA - 250W - 500 TEST
 UL/FM - 200W - 400 TEST
 CATALOG NO. C-USPO-44 W/DUCK TIPPED GASKETS
 CATALOG NO. C-USPO-45 W/PLAIN END GASKETS

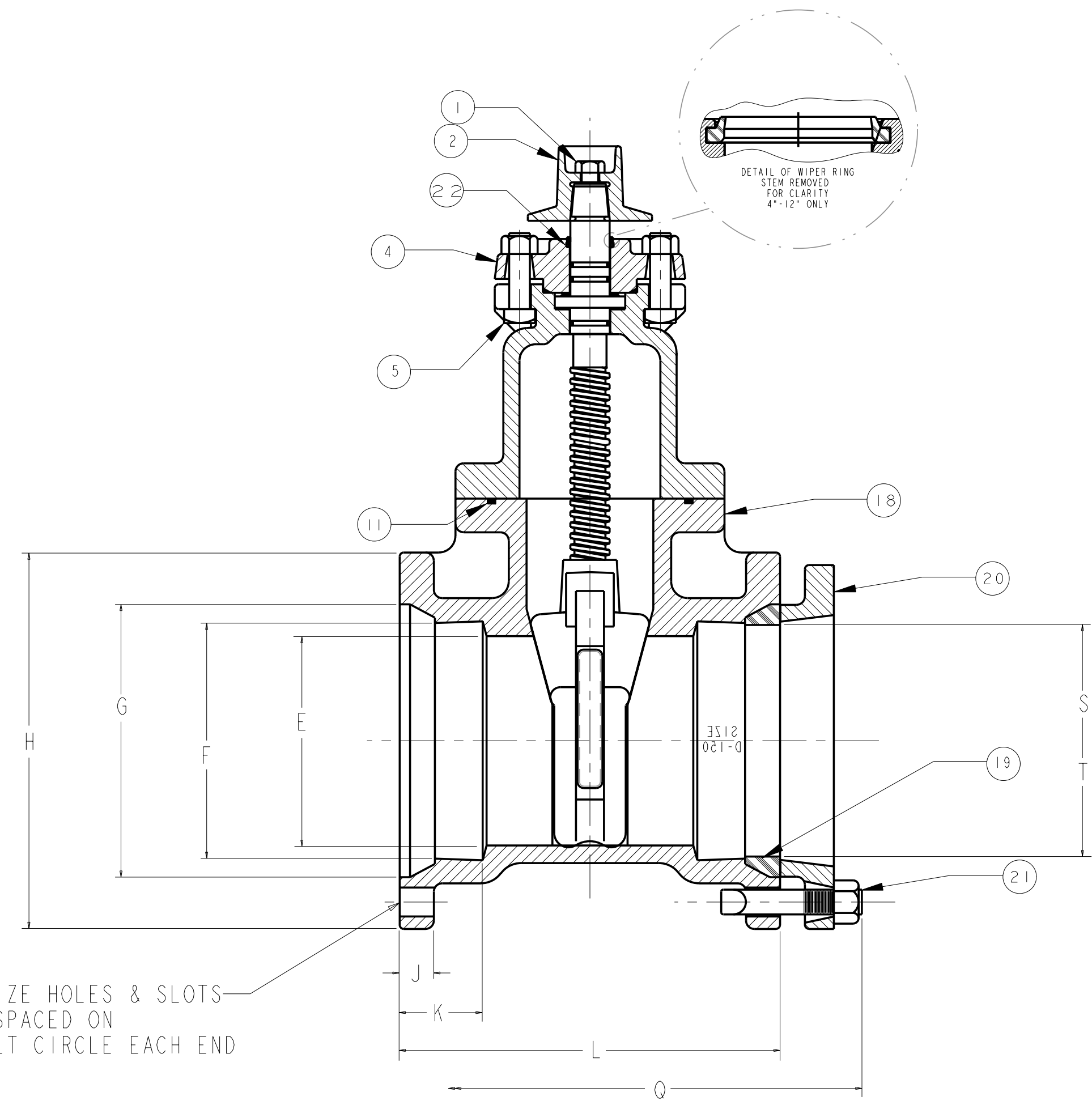
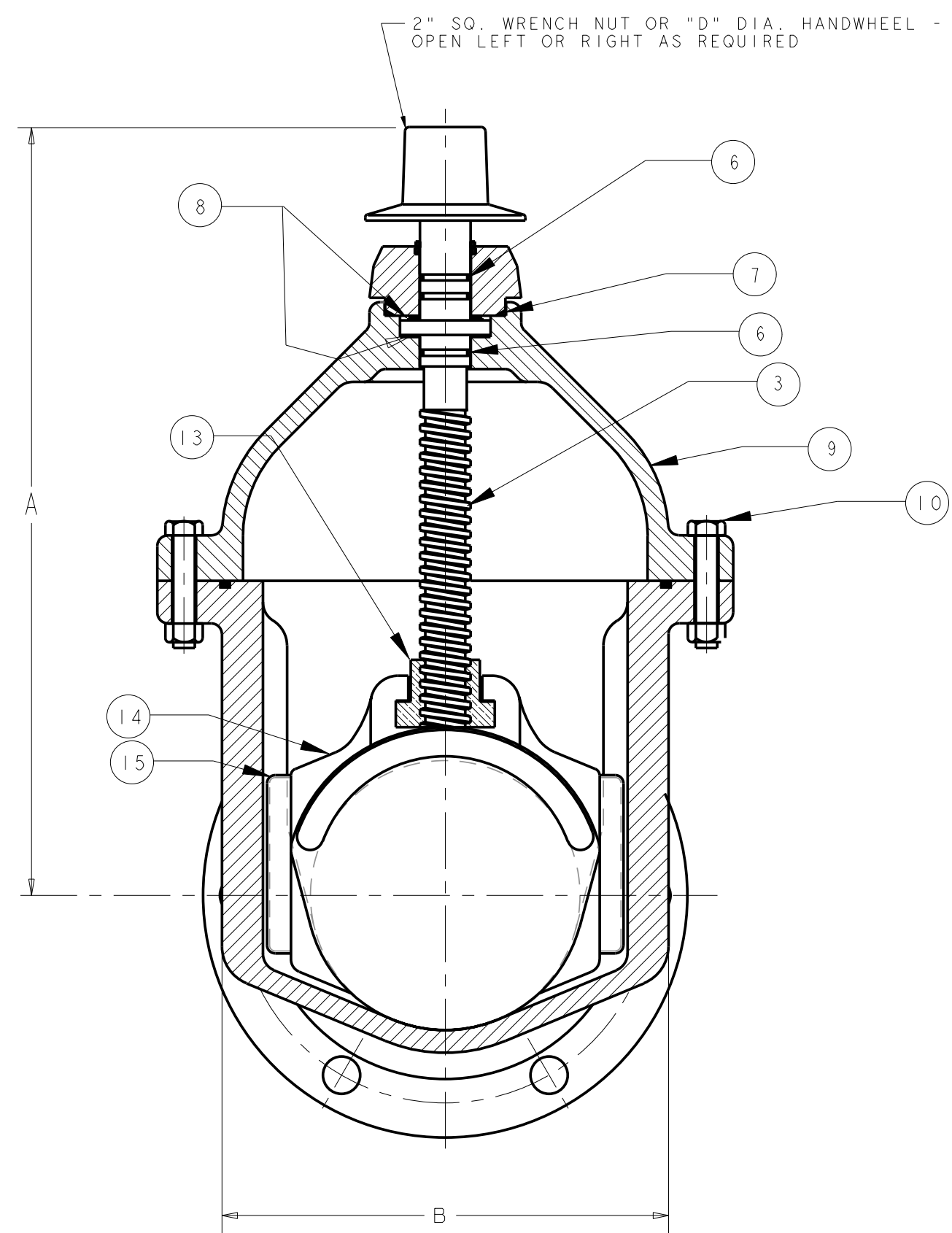
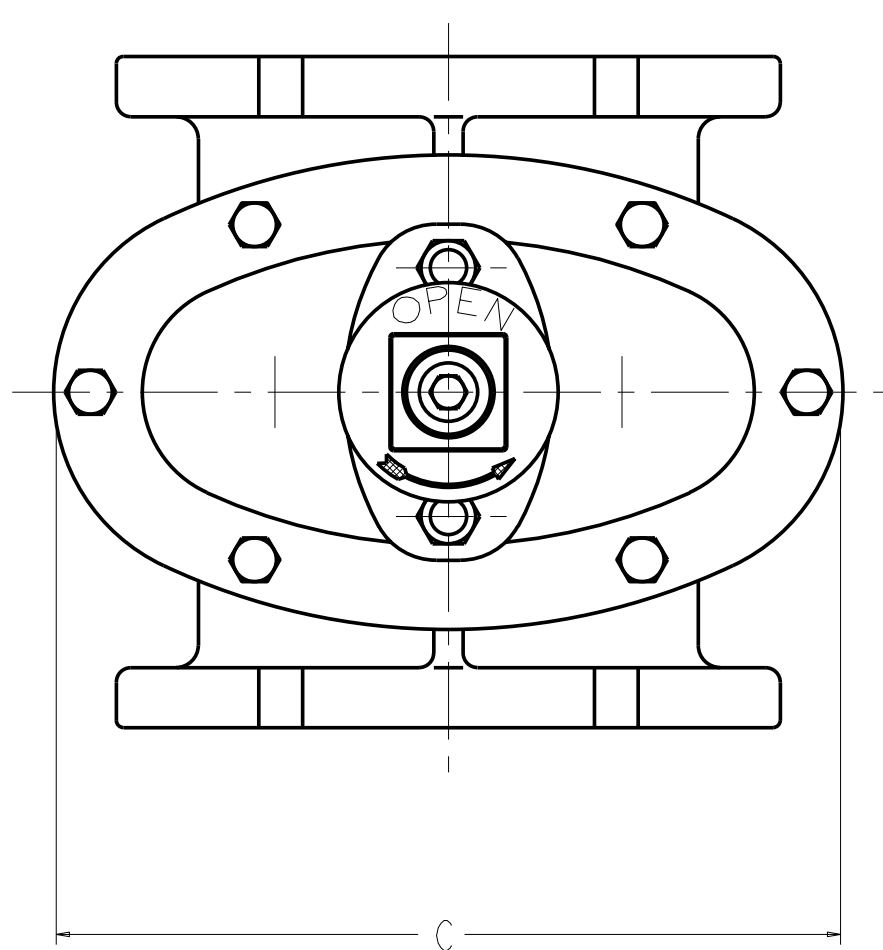

N - NO. & SIZE HOLES & SLOTS
 EQUALLY SPACED ON
 P - DIA. BOLT CIRCLE EACH END

PART LIST					
ITEM	DESCRIPTION	REQ'D	MATERIAL	ASTM	
1	CAP SCREW	1	304 STAINLESS STEEL	A193	GRADE B8
2	WRENCH NUT	1	CAST IRON	A126	CLASS B
3	STEM	1	BRONZE	B138	ALLOY C67600
4	STUFFING BOX	1	CAST IRON	A126	CLASS B
5	STUFFING BOX BOLT STUFFING BOX NUT	2	304 STAINLESS STEEL 304 STAINLESS STEEL	A193 F594	GRADE B8 GROUP 1
6	O-RING	3	RUBBER	D2000	NITRILE
7	O-RING	1	RUBBER	D2000	NITRILE
8	ANTI-FRICTION WASHER	2	CELCON		
9	BONNET	1	CAST IRON	A126	CLASS B
10	BONNET BOLT BONNET NUT	"M"	304 STAINLESS STEEL 304 STAINLESS STEEL	A193 F594	GRADE B8 GROUP 1
11	O-RING	1	RUBBER	D2000	NITRILE
13	DISC NUT	1	BRONZE	B62	ALLOY C83600
14	DISC	1	"*"		
15	GUIDE CAP	2	CELCON		
17	HANDWHEEL	1	CAST IRON	A126	CLASS B
18	BODY	1	CAST IRON	A126	CLASS B
19	MECH, JOINT GASKET	2	RUBBER	D2000	R42
20	PIPE GLAND	2	CAST IRON	A126	CLASS B
21	TEE HEAD BOLT & NUT	"R"	STEEL	A242	TYPE 1
22	WIPER RING	1	RUBBER		

* RUBBER ENCAPSULATED CAST IRON DISC
 CAST IRON - ASTM A126 - CLASS B
 RUBBER - SBR - ATM D2000

ITEMS NOS. 19, 20 & 21 AND LETTERS "Q" - "T"
 PERTAIN TO CATALOG NOS. COUSPO-44 & 45 ONLY

S - DUCK TIPPED GASKET
 - PLAIN END GASKET

DIMENSIONS FOR RESILIENT WEDGE VALVE - INCHES (this drawing only)																		
VALVE SIZE	A	B	C	D	E	F	G	H	J	K	L	M	N	P	Q	R	S	URNS TO OPEN
4	14.19	8.19	10.81	11.00	4.30	5.17	6.27	9.44	1.00	2.50	10.00	4	4	7.75	15.00	8	4.73	14
6	18.00	10.50	13.50	13.00	6.30	7.27	8.37	11.44	1.06	2.50	11.50	6	6	9.75	16.50	12	6.80	20.5
8	21.50	13.12	16.38	14.00	8.30	9.47	10.58	13.81	1.12	2.50	12.50	6	6	12.13	18.50	12	8.95	26.5

DR BY: CAP	11/14/05	UNLESS OTHERWISE NOTED	THIRD ANGLE PROJECTION	C.D. NO.
CHKD: PSG	11/14/05	BREAK CAST CORNERS!		PART. NO.
ENGR: RWV	11/14/05	BREAK MACH CORNERS!		
MFR:		TOLERANCES	PURCH. NO.	FINISH ASSY
MFG:		UNLESS OTHERWISE NOTED	REF. NO.	SCALE NONE
TOOL:		LINEAR ±	ANGULAR ±	STR. NO.
FDRT:				

NOTE
 UNITED STATES PIPE AND FOUNDRY CO.
 CHATTANOOGA TENNESSEE
 4" - 8" RWGV AUSP042
 NUMBER U6714

U6714

ECO-136164B