

VALVE SIZE	A	C	D	E	F	G	H	J	K	L	M	N	P	R	S	W	X	Y	TURNS TO OPEN	WEIGHT
16	43.58	26.58	23.50	16.00	16.06	1.59	8.03	16-1.12	21.25	12	1.10	19.75	22.56	18.40	17.28	17.91	12-.88	21.00	201	1000
18	49.41	30.50	25.00	18.38	17.00	1.69	8.50	16-1.25	22.75	12	1.06	21.00	24.88	20.74	19.64	19.00	12-.88	23.25	234	1,350
20	53.01	33.75	27.50	20.38	18.00	1.78	9.00	20-1.25	25.00	12	1.60	21.50	27.25	22.84	21.74	19.75	14-.88	25.50	258	1,800
24	59.15	39.50	32.00	24.38	20.00	2.00	10.00	20-1.38	29.50	16	1.12	23.50	31.88	27.05	25.94	21.75	16-.88	30.00	308	2,300
30	70.81	48.00	38.75	30.38	26.00	2.12	13.00	28-1.38	36.00	20	1.25	33.50	39.53	33.47	32.18	29.75	20-1.125	36.88	444	5,000
36	83.08	56.50	46.00	36.38	30.00	2.37	15.00	32-1.63	42.75	24	1.45	37.50	46.41	39.77	38.48	33.75	24-1.125	43.75	455	8,400

PARTS LIST				
ITEM	DESCRIPTION	REQ'D	MATERIAL	ASTM
1	CAP SCREW	1	STEEL	
2	WRENCH NUT	1	CAST IRON [SEE NOTE 4]	A126
3	SPUR GEARING	1		
4	STEM NUT	1	BRASS	
5	KEY	1	STEEL	
6	SOCKET HEAD SCREW	4	STEEL	SEE NOTE 2
7	GASKET	1	RUBBER	D2000
8	ADAPTER	1	STEEL	A36
9	GASKET	1	RUBBER	D2000
10	STUFFING BOX	1	STEEL	A36
11	SOCKET HEAD BOLT & NUT	4	STEEL	SEE NOTE 2
12	O-RING	1	RUBBER	D2000
13	STEM	1	BRONZE	B584
14	O-RING	3	RUBBER	D2000
15	BONNET BUSHING	1	BRONZE	B62
16	O-RING	1	RUBBER	D2000
17	WASHER	2	BRASS	
18	HEX BOLT & NUT	4	STEEL	SEE NOTE 2
19	BONNET	1	DUCTILE IRON	A536
20	EYEBOLT	2	STEEL	GALVANIZED
21	O-RING	1	RUBBER	D2000
22	HEX BOLT & NUT	"L"	STEEL	SEE NOTE 2
23	DISC NUT	1	BRONZE	B62
24	DISC	1		
25	GUIDE CAP	2	CELCON	M90
26	BODY - FLG ENDS	1	DUCTILE IRON	A536
27	BODY - MJ ENDS	1	DUCTILE IRON	A536
28	BODY FLG X MJ ENDS	1	DUCTILE IRON	A536
29	HOLD-DOWN WASHER & BOLT	1	STEEL	SEE NOTE 2
30	PIPE PLUG	1	304 STAINLESS	A193
31	ACTUATOR PIPE PLUG	1	CAST IRON	GRADE B8
32	PIPE PLUG	2	SUPPLIED WHEN TAPPED	

- NOTES:
- RUBBER ENCAPSULATED DUCTILE IRON DISC
RUBBER - SBR 16" - EPDM (18" AND UP) ASTM D2000
DUCTILE IRON ASTM A536 GRADE 65-45-12
 - BOLTS - SAE J429 GRADE 2
NUTS - ASTM A563 GRADE B
FASTENERS - PLATED TO ASTM F1941 CLASS Fe/Zn 12C
 - 16" VALVE - BRONZE ALLOY ASTM B138 ALLOY 67600
18" TO 24" VALVES - BRONZE ASTM B584 ALLOY 86400 OR 86500
30" TO 48" VALVES - BRONZE ASTM B584 ALLOY 86200 OR 86700
 - MANUFACTURER'S OPTION TO UPGRADE MATERIAL TO DUCTILE IRON A536 GRADE 65-45-12.

FLANGE END(S)
J - NO. & SIZE HOLES
K - DIA. OF BC.

MECH. JOINT END(S)
"X" - NO. & SIZE HOLES
AND OR SLOTS
EQUALLY SPACED
ON "Y" Ø BC.

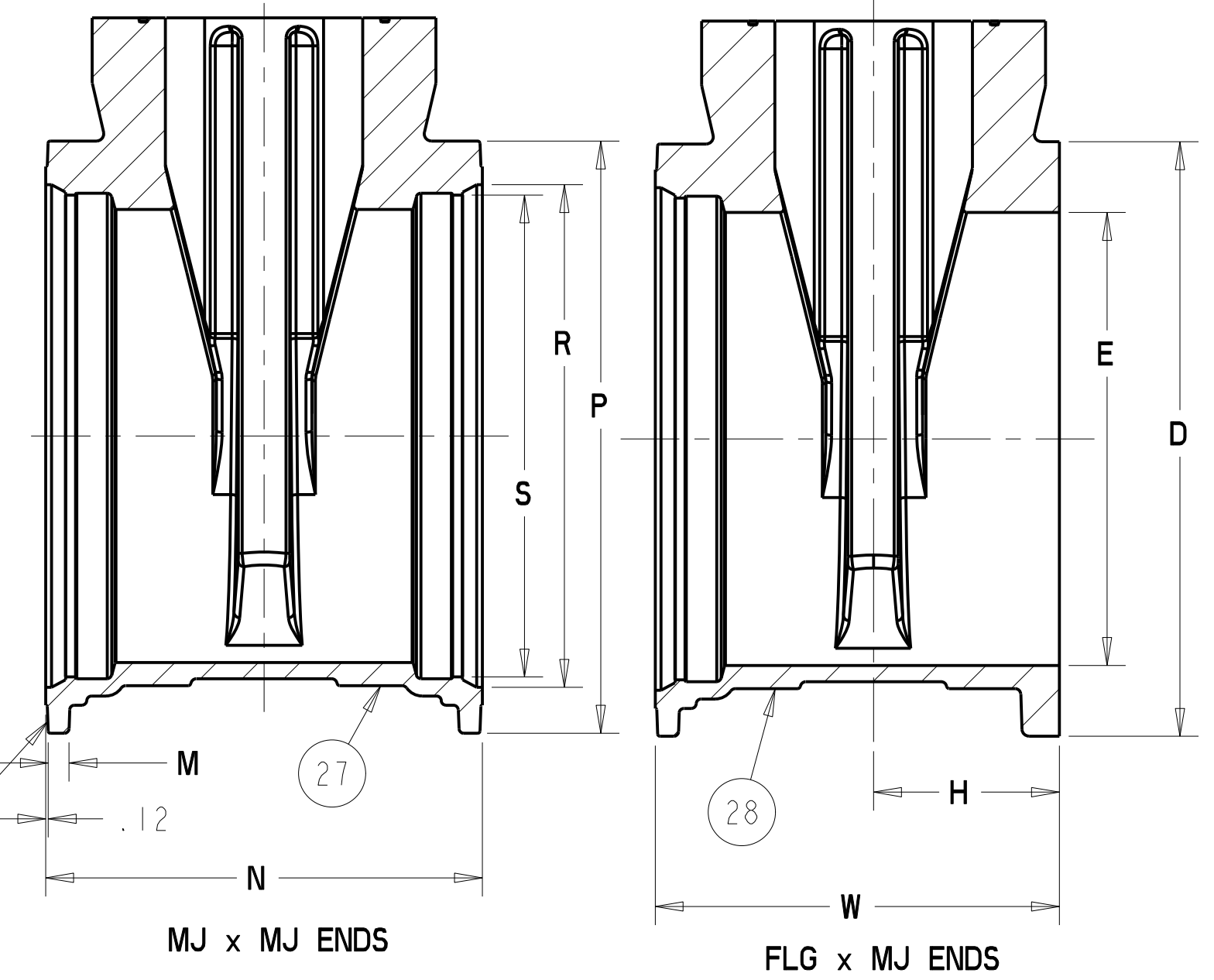

ECO 14144Z
ECO 1453431
ADDED NOTE 4
444 WAS 381
ADDED DETAILED VIEW
ADDED ITEM 32
CAP 11/12/07

ECO 1511620
REMOVED NOTE
"SIZES 24"
AND GREATER"
H.D. 7/29/09

APPROVED
By Nicholas Franklin at 3:24 pm, Aug 18, 2009

SR BY: KWE	12/1/06	UNLESS OTHERWISE NOTED	THIRD ANGLE PROJECTION	C.D. NO.
CHG: CAP	12/1/06	BREAK CAST CORNERS!		PART. NO.
ENGR: JWB	12/1/06	BREAK MACH CORNERS!		
MGR:		TOLERANCES	PURCH: NO	FINISH: ASSY
INFO:		UNLESS OTHERWISE NOTED	REF. NO.	SCALE: NONE
TOOL:		LINEAR	ANGULAR	STR. NO.
FBY:		±	±	
NOTED				
UNITED STATES PIPE AND FOUNDRY CO. CHATTANOOGA, TENNESSEE		DESCR: 16"-36" RWGV'S W/ ROTORK SPUR		NUMBER: U6739