

24" RWGV FLANGE ENDS - W/BEVEL GEARING - WITH POSITION INDICATOR - WITH OR WITHOUT BOTTOM BY-PASS

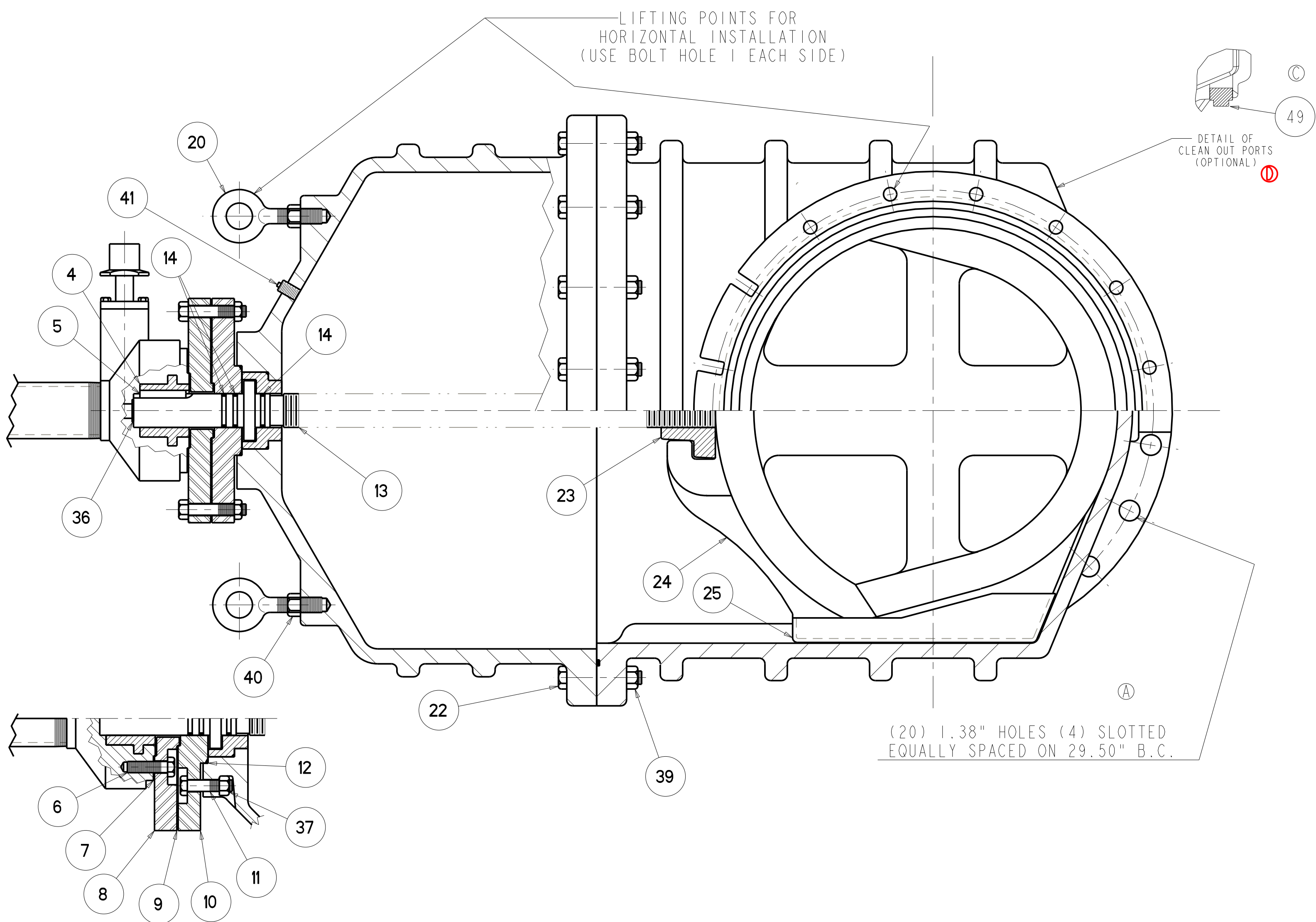

SECTION A

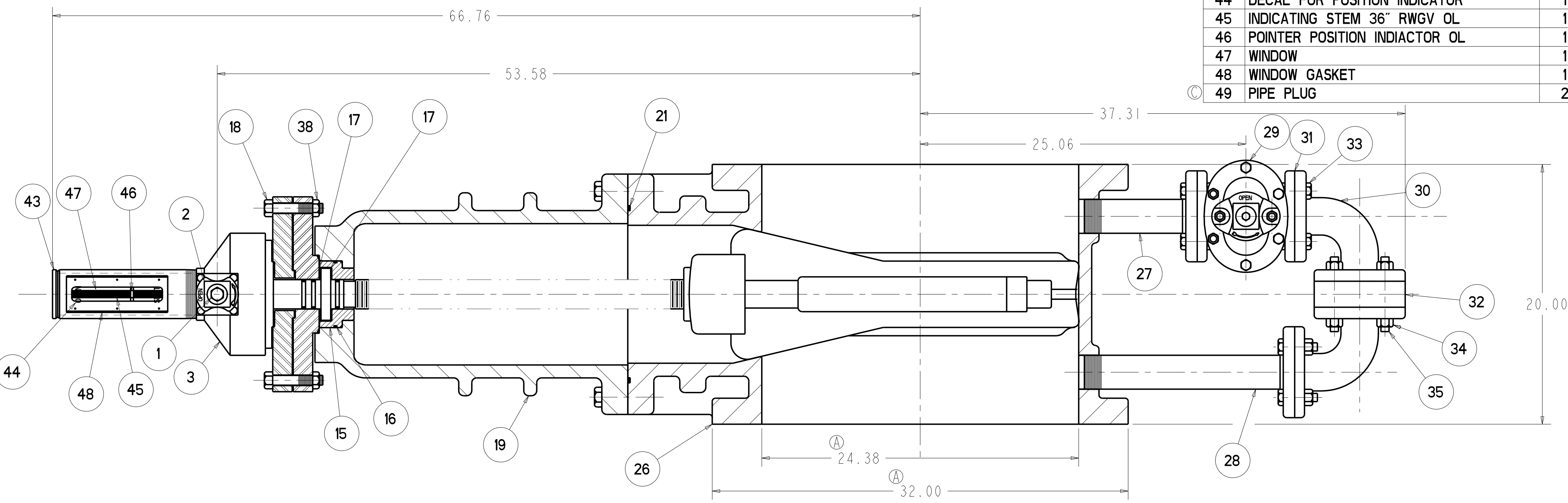

PARTS LIST - 240A236106LN 06E396

ITEM	DESCRIPTION	REQ'D	MATERIAL	ASTM	CLASS B	NOTES
1	CAP SCREW 8mm X 30mm	1	316 STAINLESS STEEL			
2	WRENCH NUT	1	CAST IRON (SEE NOTE 4)	A126	CLASS B	
3	BEVEL GEAR UNIT	1	MASTERGEAR A13			
4	STEM NUT	1	BRASS			
5	KEY 1/2" X 3 1/2"	1	316 STAINLESS STEEL	A193		
6	SOCKET HEAD SCREW 5/8" X 1 3/4"	4	316 STAINLESS STEEL	A193		
7	GASKET	1	RUBBER	D2000		
8	ADAPTER	1	IRON	A126	CLASS B	MAY SUBSTITUTE STEEL
9	O-RING 4 1/8" X 4 3/8" X 1/8" #243	1	RUBBER	D2000		EPDM (B)
10	STUFFING BOX W/ SPUR GEARING	1	IRON	A126	CLASS B	MAY SUBSTITUTE STEEL
11	SOCKET HEAD BOLT 7/8" X 4 1/4"	4	316 STAINLESS STEEL	A193		
12	O-RING 5 5/8" X 6" X 3/16" #358	1	RUBBER	D2000		EPDM (B)
13	STEM	1	BRONZE			SEE NOTE 3 (B)
14	O-RING 2 3/8" X 2 3/4" X 3/16" #332	3	RUBBER	D2000		EPDM (B)
15	BONNET BUSHING	1	BRONZE	B62		
16	O-RING 4 7/8" X 5 1/8" X 1/8" #249	1	RUBBER	D2000		EPDM (B)
17	WASHER	2	BRASS			
18	HEX BOLT 3/4" X 4"	4	316 STAINLESS STEEL	A193		
19	BONNET	1	DUCTILE IRON	A536	GR. 65-45-12	
20	EYEBOLT 1 1/4"	2	STEEL		GALVANIZED	
21	O-RING	1	RUBBER	D2000		EPDM
22	HEX BOLT 1" X 7 1/2"	16	316 STAINLESS STEEL	A193		
23	DISC NUT	1	BRONZE	B62		
24	DISC	1				SEE NOTE 1
25	GUIDE CAP	2	CELCON		M90	
26	BODY	1	DUCTILE IRON	A536	GR. 65-45-12	
27	PIPE NIPPLE W/FLG SHORT	1	STEEL			
28	PIPE NIPPLE W/FLG LONG	1	STEEL			
29	BY-PASS VALVE	1				SEE NOTE 2
30	90° ELBOW LONG	2	CAST STEEL			
31	FLANGE GASKET	5	RUBBER	D2000		
32	SPACER	1	STEEL	A36		
33	HEX BOLT 5/8" X 2 3/4"	12	316 STAINLESS STEEL	A193		
34	HEX NUT 5/8"	20	316 STAINLESS STEEL	A194		
35	STUD 5/8" X 5 1/2"	4	316 STAINLESS STEEL			
36	HOLD-DOWN WASHER 5/8"	1	316 STAINLESS STEEL			
37	HEAVY HEX NUT 7/8"	4	316 STAINLESS STEEL	A194		
38	HEX NUT 3/4"	4	316 STAINLESS STEEL	A194		
39	HEX NUT 1"	16	316 STAINLESS STEEL	A194		
40	HEAVY HEX NUT 1 1/4"	2	STEEL			
41	SQUARE HEAD PIPE PLUG 1/4" - 18 NPT	1	316 STAINLESS STEEL			
42	84 X 40 PALLET	1	WOOD		NOT SHOWN	
43	HOUSING SUB ASSEMBLY	1	STEEL			
44	DECAL FOR POSITION INDICATOR	1				
45	INDICATING STEM 36" RWGV OL	1	BRONZE			
46	POINTER POSITION INDICATOR OL	1	BRONZE			
47	WINDOW	1	PLEXIGLAS OR LEXAN			
48	WINDOW GASKET	1				
49	PIPE PLUG	2				SUPPLIED WHEN TAPPED

- NOTES:
- (B) RUBBER ENCAPSULATED DUCTILE IRON DISC
RUBBER - EPDM ASTM D2000
DUCTILE IRON ASTM A536 GRADE 65-45-12
 - (2) 2. BY-PASS VALVE - 2" RWGV - FLANGE ENDS
 - (3) 18" TO 24" STEM - BRONZE ASTM B763 ALLOY 99400 OR 99500
 - (C) MANUFACTURER'S OPTION TO UPGRADE MATERIAL TO DUCTILE IRON A536 GRADE 65-45-12
 - (5) VALVE WILL BE FURNISHED WITH ONE OF THE LISTED OPERATORS AT THE MANUFACTURER'S DISCRETION. MASTERGEAR A13, RATIO 4.5:1, TURNS TO OPEN 338 ROTORK HOB414, RATIO 4:1, TURNS TO OPEN 300

SR BY	CAP	11/17/05	UNLESS OTHERWISE NOTED	THIRD ANGLE PROJECTION	C.D. NO.
CHNG	PSG	11/17/05	BREAK CAST CORNERS!		
ENGR	RWV	11/17/05	BREAK MACH CORNERS!		
MGR				PURCH	FINISH
INFO			TOLERANCES	NO	ASSY
TOOL			UNLESS OTHERWISE NOTED	REF. NO.	SCALE
FBRY			L INEAR	ANGULAR	NONE
			±	±	STR. NO.
NOTED					
UNITED STATES PIPE AND FOUNDRY CO. CHATTANOOGA TENNESSEE			DESCR: 24" FLANGE ENDS RWGV W/BEVEL GEARING & POSITION INDICATOR WITH OR WITHOUT BTM BY-PASS		NUMBER U6746

APPROVED
By Nicholas Franklin at 3:24 pm, Aug 18, 2009