

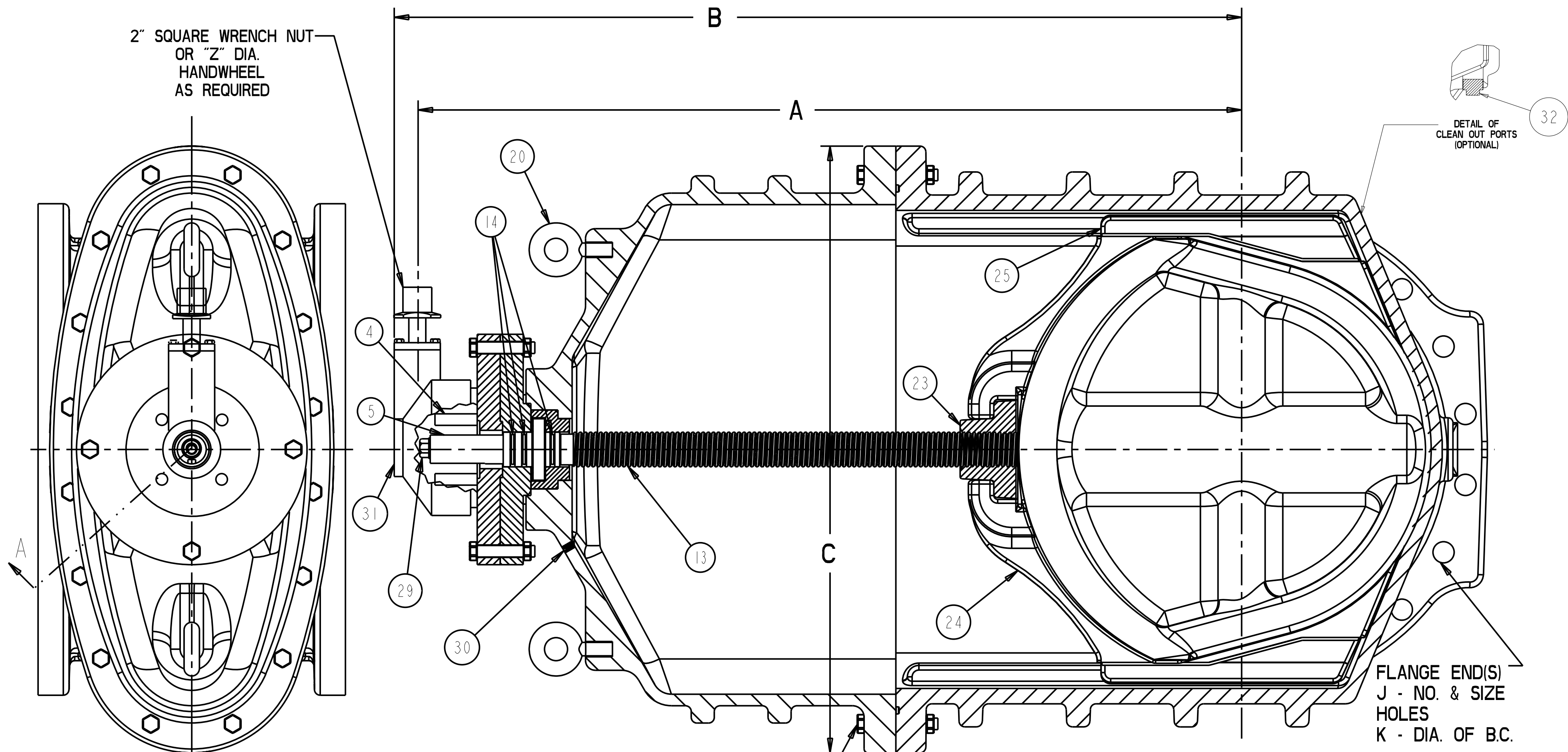

U6862 16"-36" RWGV & RTV W/ BEVEL GEAR & 304 SS FASTENERS

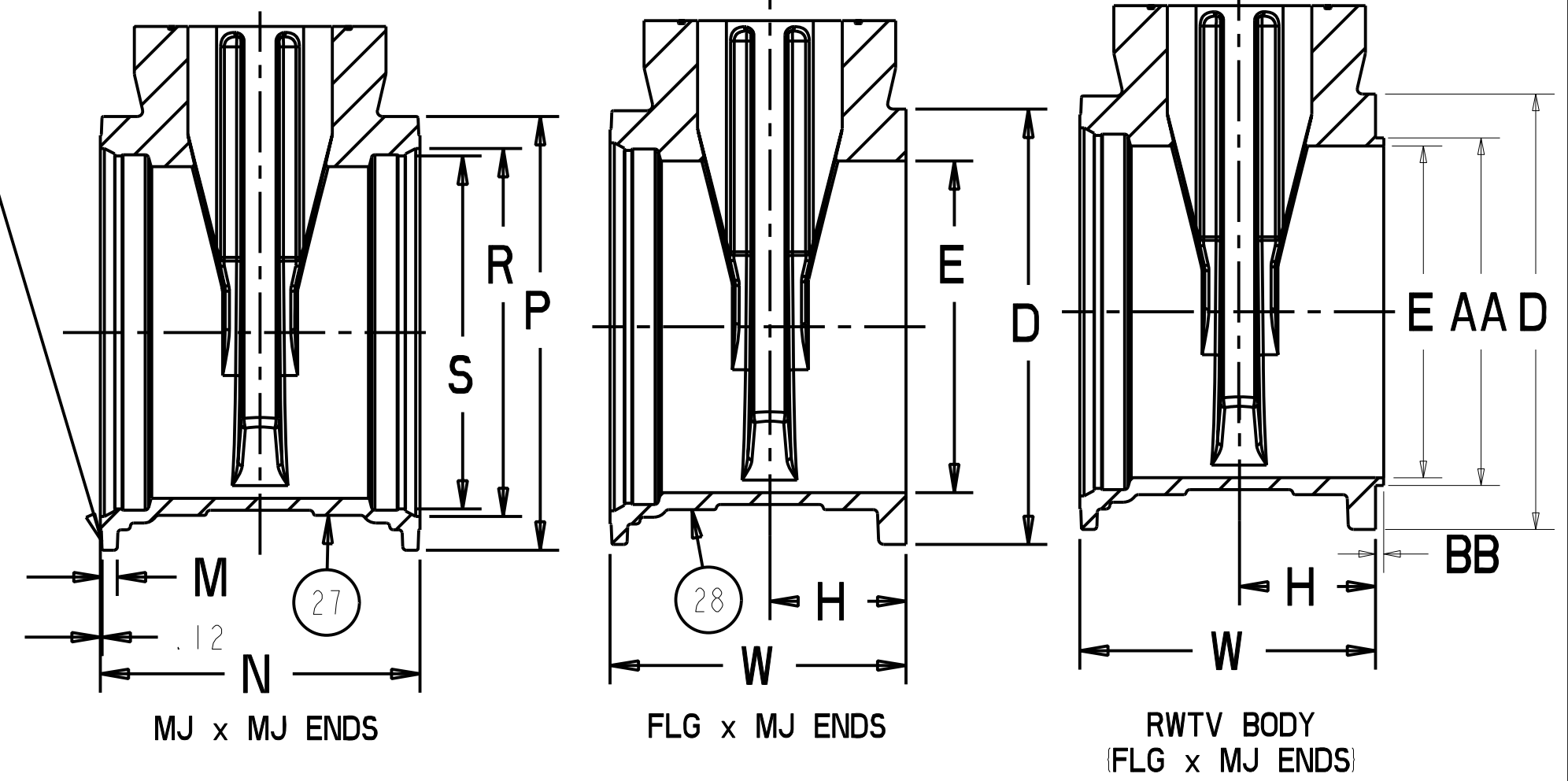

PARTS LIST					
ITEM	DESCRIPTION	REQ'D	MATERIAL	ASTM	
1	CAP SCREW	1	304 STAINLESS		SEE NOTE 2
2	WRENCH NUT	1	CAST IRON [SEE NOTE 5]	A126	
3	BEVEL GEAR UNIT	1			SEE NOTE 3
4	STEM NUT	1	BRASS		
5	KEY	1	STEEL		
6	SOCKET HEAD SCREW	4	304 STAINLESS		SEE NOTE 2
7	GASKET	1	RUBBER	D2000	
8	ADAPTER	1	STEEL	A36	
9	GASKET	1	RUBBER	D2000	
10	STUFFING BOX	1	STEEL	A36	
11	SOCKET HEAD BOLT & NUT	4	304 STAINLESS		SEE NOTE 2
12	O-RING	1	RUBBER	D2000	R34 16" EPDM 18"-36"
13	STEM	1	BRONZE		SEE NOTE 4
14	O-RING	3	RUBBER	D2000	R34 16" EPDM 18"-36"
15	BONNET BUSHING	1	BRONZE	B62	18"-36" ONLY
16	O-RING	1	RUBBER	D2000	R34 16" EPDM 18"-36"
17	WASHER	2	BRASS		
18	HEX BOLT & NUT	4	304 STAINLESS		SEE NOTE 2
19	BONNET	1	DUCTILE IRON	A536	GR. 65-45-12
20	EYEBOLT	2	STEEL		GALVANIZED
21	O-RING	1	RUBBER	D2000	R34 16" EPDM 18"-36"
22	HEX BOLT & NUT	"L"	304 STAINLESS		SEE NOTE 2
23	DISC NUT	1	BRONZE	B62	
24	DISC	1			SEE NOTE 1
25	GUIDE CAP	2	CELCON		M90
26	BODY - FLG ENDS	1	DUCTILE IRON	A536	GR. 65-45-12
27	BODY - MJ ENDS	1	DUCTILE IRON	A536	GR. 65-45-12
28	BODY FLG X MJ ENDS	1	DUCTILE IRON	A536	GR. 65-45-12
29	HOLD-DOWN WASHER & BOLT	1	304 STAINLESS		SEE NOTE 2
30	PIPE PLUG	1	304 STAINLESS	A193	GRADE B8
31	ACTUATOR CAP PLUG	1	CAST IRON [SEE NOTE 5]		
32	PIPE PLUG	2	SUPPLIED WHEN TAPPED		

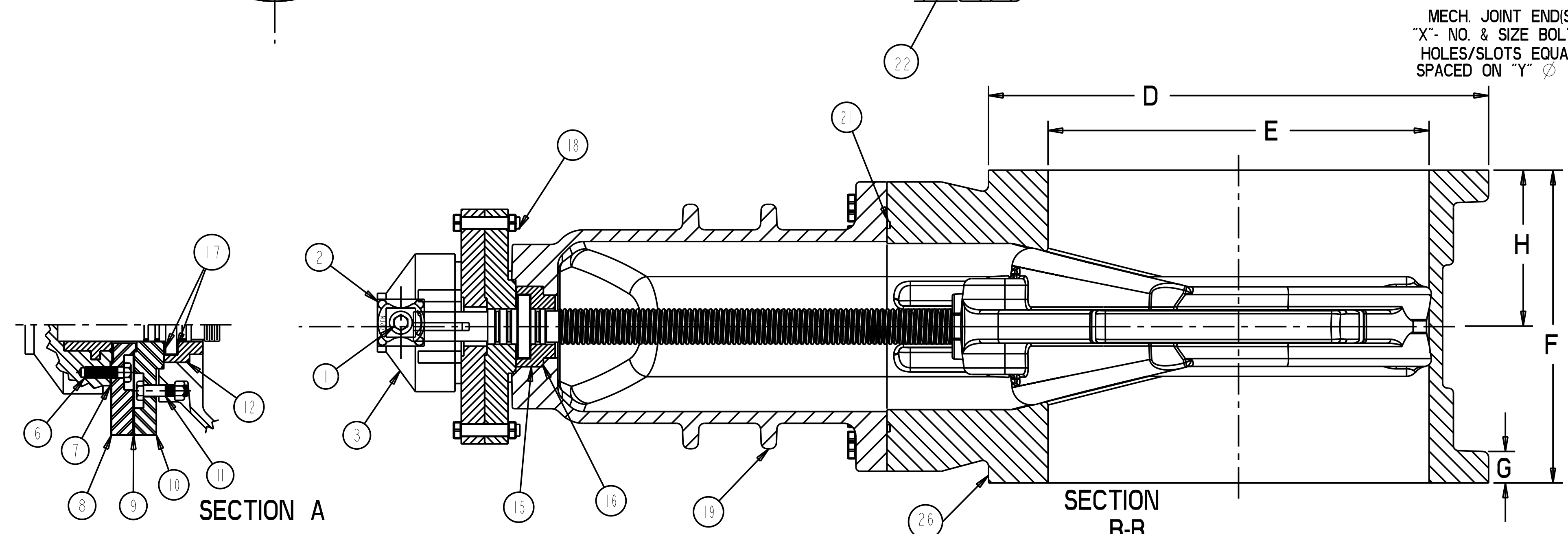

- NOTE:
- RUBBER ENCAPSULATED DUCTILE IRON DISC  
RUBBER - EPDM ASTM D2000  
DUCTILE IRON ASTM A536 GRADE 65-45-12
  - BOLTS - ASTM A193 GRADE B8  
NUTS - ASTM F594 GROUP 1
  - VALVES WILL BE FURNISHED WITH ONE OF THE LISTED OPERATORS AT THE MANUFACTURER'S DISCRETION.  
16"-24" MASTERGEAR OR ROTORK  
30" & 36" LIMITORQUE OR ROTORK
  - 16" VALVE - BRONZE ALLOY ASTM B138 ALLOY 67600  
18" TO 24" VALVE - BRONZE ASTM B584 ALLOY 86400 OR 86500  
30" TO 48" VALVES - BRONZE ASTM B584 ALLOY 86200 OR 86700
  - MANUFACTURER'S OPTION TO UPGRADE MATERIAL TO DUCTILE IRON A536 GRADE 65-45-12

VALVE SIZE	A	B	C	D	E	F	G	H	J	K	L	M	N	P	R	S	W	X	Y	Z	AA	BB	TURNS TO OPEN MASTERGEAR, RATIO 4.5:1 LIMITORQUE, RATIO 4:1	TURNS TO OPEN ROTORK, RATIO 4:1	EST. WEIGHT
16	39.24	37.03	26.58	23.50	16.00	16.06	1.59	8.03	16-1.20	21.25	12	1.10	19.75	22.56	18.40	17.28	17.91	12-.875	21.00	12.00	17.23	0.25	221	196	1,000
18	44.50	46.06	30.50	24.88	18.38	17.00	1.69	8.50	16-1.25	22.75	12	1.06	21.00	24.88	20.74	19.64	19.00	12-.875	23.25	12.00	19.45	0.25	257	228	1,350
20	47.69	49.25	33.75	27.50	20.38	18.00	1.78	9.00	20-1.25	25.00	12	1.60	21.50	27.25	22.84	21.74	19.75	14-.875	25.50	12.00	21.45	0.25	284	252	1,800
24	54.06	55.50	39.50	32.00	24.38	20.00	2.00	10.00	20-1.38	29.50	16	1.12	23.50	31.88	27.05	25.94	21.75	16-.875	30.00	12.00	25.43	0.25	338	300	2,300
30	64.93	66.52	48.00	38.75	30.38	26.00	2.12	13.00	28-1.38	36.00	20	1.25	33.50	39.53	33.47	32.18	29.75	20-1.125	36.88	18.00	30.94	.516	372	372	5,100
36	77.19	78.75	56.50	46.00	36.38	30.00	2.37	15.00	32-1.63	42.75	24	1.45	37.50	46.41	39.77	38.48	33.75	24-1.125	43.75	18.00	36.94	.516	444	444	8,400

**APPROVED**  
By Charles Hines at 3:35 pm, May 13, 2010

DR BY: JAD 05/13/10	UNLESS OTHERWISE NOTED	THIRD ANGLE PROJECTION	C.D. NO.
CHKD: CGH 05/13/10	BREAK CAST CORNERS!		PART. NO.
ENGR: RWV 05/13/10	BREAK MACH CORNERS!		
MFG:	TOLERANCES	PURCH: NO	FINISH: ASSY
INFO:	UNLESS OTHERWISE NOTED	REF. NO.	SCALE: NONE
TOOL:	LINEAR	ANGULAR	STR. NO.
FBY:	±	±	
MATERIAL: NOTED			
UNITED STATES PIPE AND FOUNDRY CO. CHATTANOOGA, TENNESSEE		DESCR: 16"-36" RWGV & RTV W/ BEVEL GEAR & 304 SS FASTENERS	NUMBER: U6862