

No.	DESCRIPTION	MATERIAL DESCRIPTION
1	SPUD	CAST LOW LAD BRASS ALLOY
2	PJ GASKET	ASTM D2000 (BUNA N)
3	WASHER	POLYPROPYLENE
4	CLPG NUT SUB	CAST BRASS ASTM B62 ALLOY C83600

SIZE	A	B	NPT
3/4"	1.72	1.79	3/4"
1"	2.00	2.00	1"
1 1/2"	2.38	2.75	1 1/2"
2"	2.84	3.09	2"

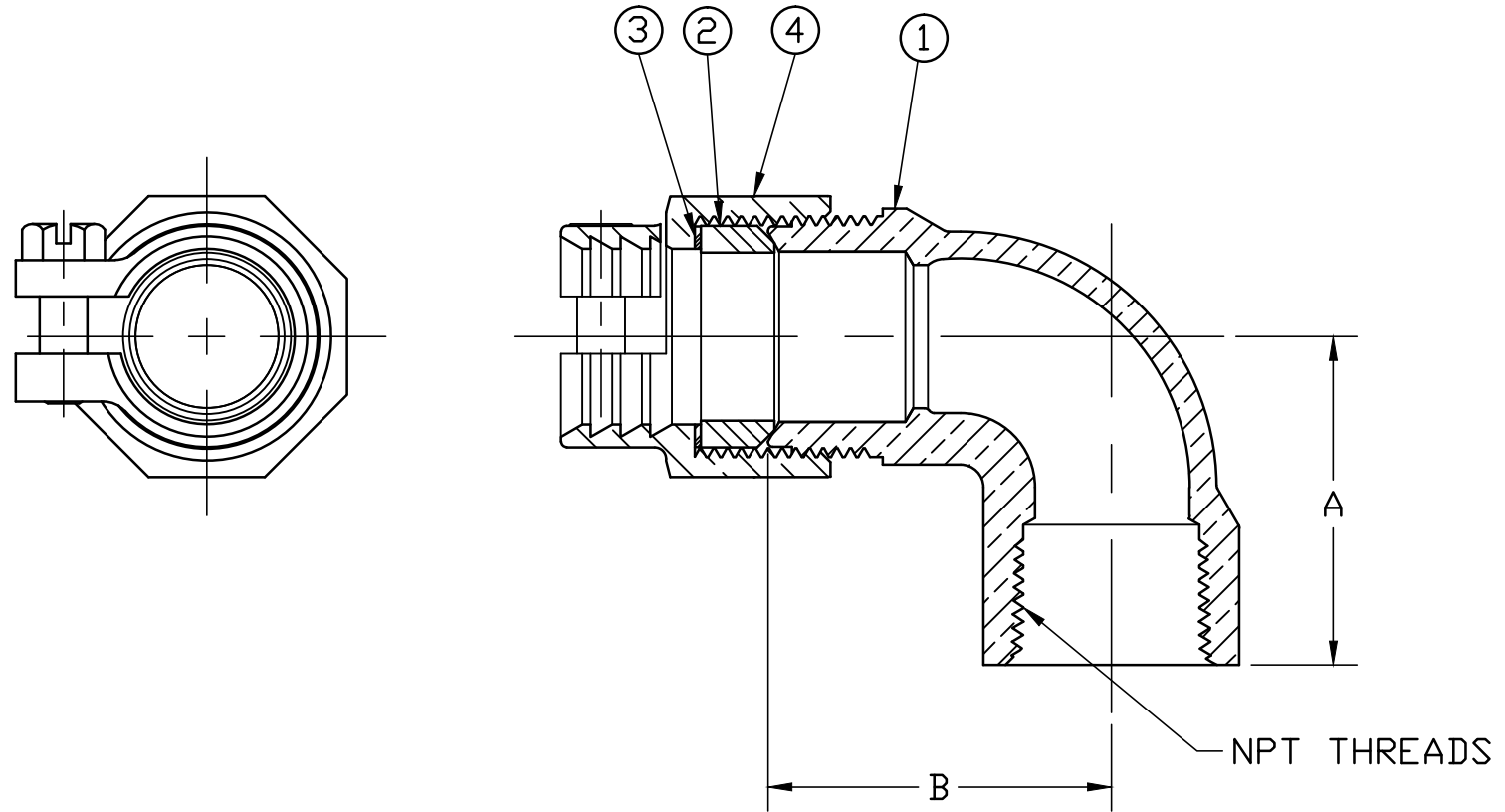

ALL WETTED PARTS ARE LOW LEAD BRASS ALLOY

FILEPATH: PROD-ENG\JAMESJONES\SUBMITTALS\E2621

						DRFTR	RWB	4/22/16	JONES		
						CHKR					
						ENGR					
						MGR					
							BY	DATE	UNLESS OTHERWISE NOTED	THIRD ANGLE PROJECTION	
									SURFACE PREPARATION:		
									BREAK CORNER(S) ---- .000		REF. No.
									SURFACE FINISH --XX RMS		FULL
									TOLERANCE(S):		
									LINEAR ----- ± .000		
									ANGULAR ----- ± 0°00'		
									STK No:		
									MAT'L:		
									DESCR.		
									QUARTER BEND LLB UNION SERVICE FITTING		DWG NUMBER
									(FIP x PJ CTS)		E2621
REV	ECR	DESCRIPTION	DATE	BY	CHKR						

DWG NUMBER
E2621
JJ-MRKTG

TITLE TO AND OWNERSHIP OF THIS ENGINEERING DATA REMAINS IN Mueller Co. NO USE IS TO BE MADE OF THIS DATA EXCEPT AS SPECIFICALLY AUTHORIZED BY Mueller Co. ASSENT ON THE PART OF THE RECIPIENT TO THESE CONDITIONS IS PRESUMED