

No.	DESCRIPTION	MATERIAL
1	SPUD	CAST LOW LEAD BRASS ALLOY
2	CONN. NUT	CAST BRASS ASTM B62 ALLOY C83600
3	CTS GSKT SUB	SBR ASTM D2000 - GSKT 410ss - BAND

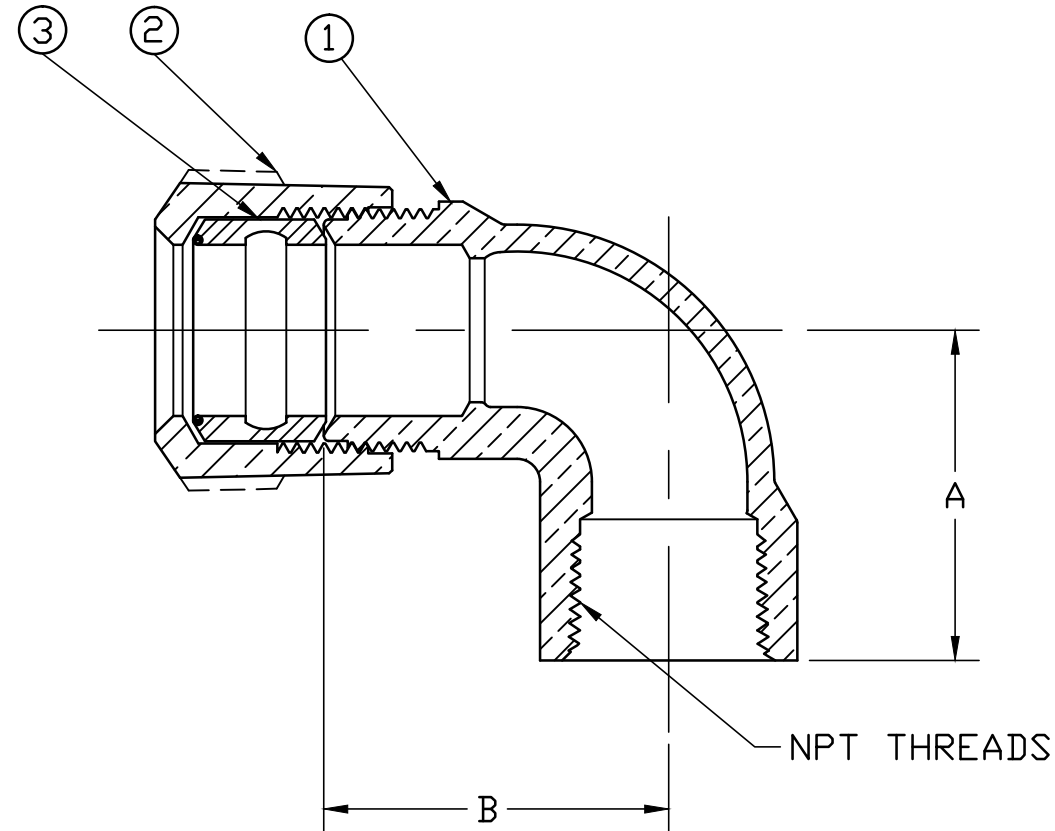

SIZE	A	B	NPT SIZE
3/4	1.72	1.79	3/4"
1	2.00	2.00	1"
1-1/2	2.38	2.75	1-1/2"
2	2.84	2-31/32"	2"

ALL WETTED PARTS ARE LOW LEAD BRASS ALLOY

FILEPATH: PROD-ENG\JJ\SUBMITTALS\E2621SG

						DRFTR	JGarvin	9/29/10	<b>JONES</b>	UNLESS OTHERWISE NOTED THIRD ANGLE PROJECTION	
						CHKR					SURFACE PREPARATION: BREAK CORNER(S) ---- .000 SURFACE FINISH -- XX RMS TOLERANCE(S): LINEAR ----- ± .000 ANGULAR ----- ± 0°00'
						ENGR				REF. No.	
						MGR					
								BY	DATE		
								STK No:			
								MAT'L:			
								DESCR.	QUARTER BEND UNION SERVICE FITTING (FIP x 110 CTS) LOW LEAD BRASS	DWG NUMBER E2621SG	
REV	ECR	DESCRIPTION	DATE	BY	CHKR						

TITLE TO AND OWNERSHIP OF THIS ENGINEERING DATA REMAINS IN Mueller Co. NO USE IS TO BE MADE OF THIS DATA EXCEPT AS SPECIFICALLY AUTHORIZED BY Mueller Co. ASSENT ON THE PART OF THE RECIPIENT TO THESE CONDITIONS IS PRESUMED

DWG NUMBER  
E2621SG  
JJ-MRKTG