

No.	DESCRIPTION	REQ'D	MATERIAL
1	COUPLING NUT W/ SCREW	2	CAST BRASS ASTM B62 ALLOY C83600
2	COMPRESSION GASKET	2	D2000 SBR RUBBER
3	PLASTIC WASHER	2	POLYPROPYLENE PLASTIC
4	BRANCH CONNECTION	1	CAST LOW LEAD BRASS ALLOY

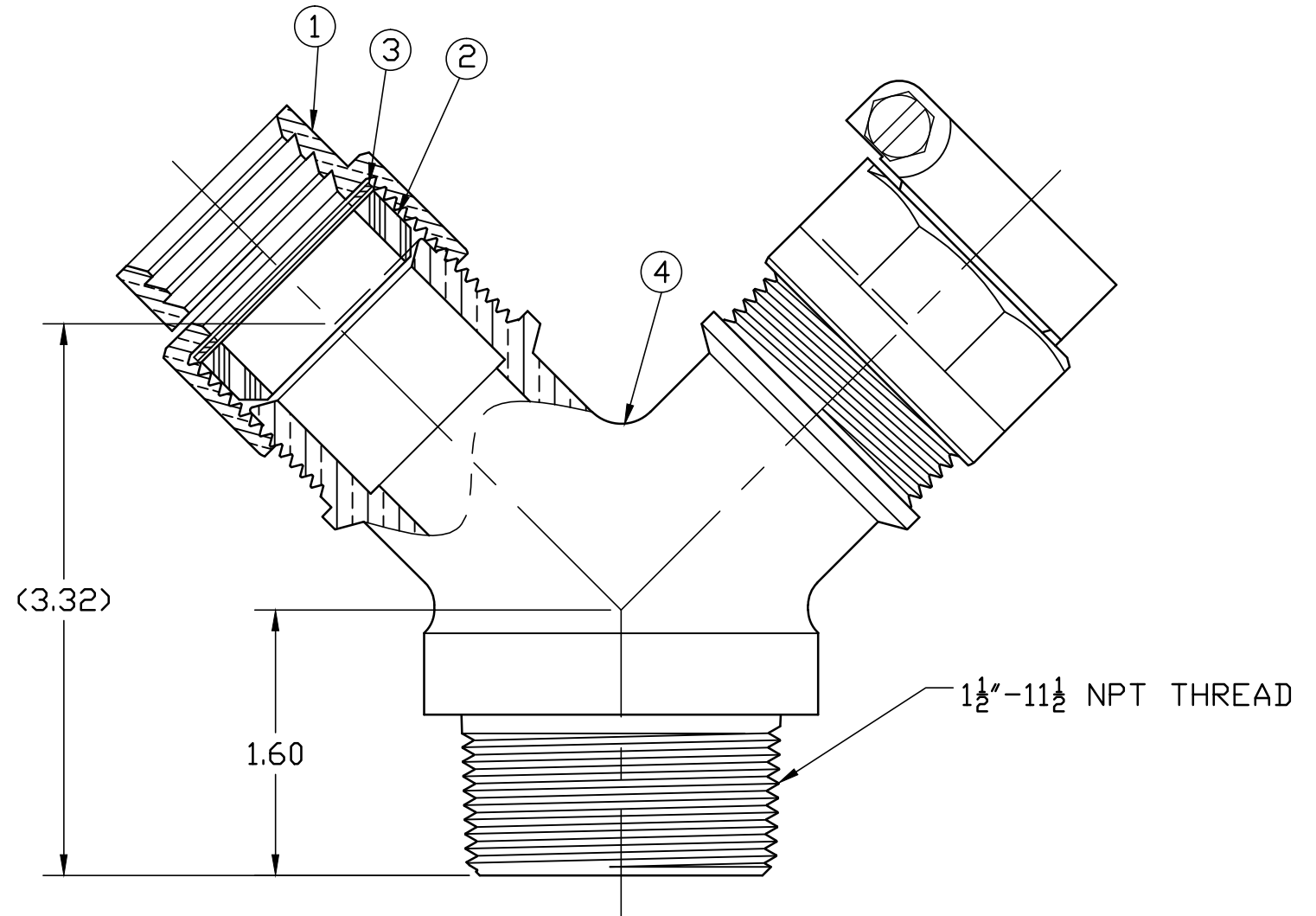

ALL WETTED PARTS ARE LOW LEAD BRASS ALLOY

FILEPATH: PROD-ENG\JAMESJONES\APPROVED\E2630

						DRFTR	RWB	4/25/16	<b>JONES</b>		
						CHKR					
						ENGR					
						MGR					
									UNLESS OTHERWISE NOTED	THIRD ANGLE PROJECTION	
									SURFACE PREPARATION:		
									BREAK CORNER(S) ---- .000		
									SURFACE FINISH -- 000 RMS	REF. No.	SCALE
									TOLERANCE(S):		FULL
									LINEAR ----- ± .016		
									ANGULAR ----- ± 0°30'		
								STK No:			
								MAT'L:			
								DESCR.	1" x 1-1/2" LLB "Y" BRANCH CONNECTION	DWG NUMBER	
									PJ "CTS" x MIP OUTLET SHORT BODY	E2630	
								PER EST NO: DXXXX EST FIN WT = 0.0000 lbs			

DWG NUMBER  
E2630

JJ-MRKTNG

TITLE TO AND OWNERSHIP OF THIS ENGINEERING DATA REMAINS IN Mueller Co. NO USE IS TO BE MADE OF THIS DATA EXCEPT AS SPECIFICALLY AUTHORIZED BY Mueller Co. ASSENT ON THE PART OF THE RECIPIENT TO THESE CONDITIONS IS PRESUMED.